

使用說明書

變頻二合一空氣淨化抽濕機

RAD-DA11HK-1

RAD-DA13HK

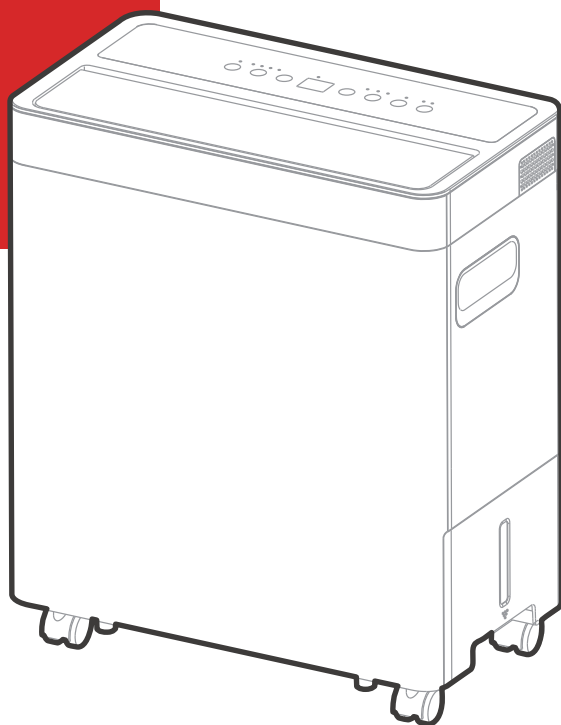

重要提示：

在使用本產品前，請仔細閱讀本手冊，
並妥善保管以備日後參考。

設計和規格如有更改，恕不另行通知。

TOSHIBA

目錄

安全注意事項	3
了解產品	10
部件識別	
定位裝置	
使用產品時	
了解功能	13
控制面板功能	
傾倒積水	16
水桶排水 (類型 1)	
水管排水 (連續) (類型 2)	
保養與維修	18
清潔格柵和外殼	
清潔水桶	
清潔空氣過濾器	
長期不用機器時	
故障排除	20

安全注意事項

閱讀《操作和安裝前安全注意事項》非常重要。由於忽略本說明而導致安裝不當，可能導致嚴重損壞或傷害。

潛在損害或傷害的嚴重性分為警告或注意。

符號說明

⚠ 警告

此警示詞表示危險程度較高，如果不避免，可能導致嚴重傷害或死亡。

⚠ 注意

此警示詞表示風險程度較低的危險，如果不避免，則可能導致輕微或中度傷害。

在使用/調試抽濕機前，請仔細閱讀這些操作說明，並妥善儲存在裝置安裝現場附近以備日後使用！

⚠ 警告

- 不要超過電源插座或連接裝置的額定值。
- 請勿透過開啟或切斷電源來操作或停止本裝置。
- 請勿損壞電源線，或使用非指定的電源線。
- 請勿更改電源線長度或與其他電器共用插座。
- 不要用濕手插拔插頭。
- 抽濕機不得安裝在可能接觸可燃氣體的位置。
- 抽濕機不要靠近熱源。
- 如果發出奇怪的聲音、氣味或煙霧，請斷開電源。
- 絕不要試圖自行拆開或修理抽濕機。
- 清潔抽濕機前關閉電源並拔掉插頭。
- 不要在易燃氣體或可燃物如汽油、苯、稀釋劑等附近使用抽濕機。
- 不要飲用或使用從抽濕機中排出的水。
- 抽濕機工作時請勿取出水桶。
- 抽濕機上不得放置可能濺水的物品。
- 抽濕機宜放置在牢固的水平地板上。
- 勿用布或毛巾覆蓋進排氣口。
- 房間裡若有以下人員應小心使用抽濕機：嬰兒、兒童、老人和對濕度不敏感的人。
- 不要在處理化學品的區域使用抽濕機。
- 絕不要用手指或其他異物插入抽濕機格柵或開口。特別注意對孩子們警告上述危險。
- 重物不要放在電源線上，小心不要擠壓電源線。
- 不要攀爬或坐在抽濕機上。
- 始終安全插入空氣過濾器。每兩週清潔一次空氣過濾器。
- 如果水進入抽濕機，請關閉裝置並斷開電源，聯絡合格的維修技術員。
- 勿在抽濕機頂部放置花瓶或其他裝水容器。
- 不要使用加長電源線。

⚠ 注意

- 不低於 8 歲的兒童，身體、感官或精神能力下降或缺乏經驗常識的人員，如果給予他們關於安全使用本抽濕機的監督或指導，並了解相關風險，可以使用本裝置。兒童不得玩弄抽濕機。不得由兒童在無監督情況下執行其清潔和用戶維護。（適用於歐洲國家）
- 本抽濕機對於身體、感官或精神能力下降或缺乏經驗常識的人員（包括兒童）不適用，除非給予他們關於安全使用本抽濕機的監督或指導。兒童應受監督，確保他們不玩弄抽濕機。（適用於除歐洲國家以外的其他國家或地區）
- 如果電源線損壞，必須由製造商、其服務代理或類似的合格人員更換，以避免危險。
- 在執行清潔或其他維護作業前，必須斷開抽濕機的電源。
- 抽濕機不得安裝在可能接觸可燃氣體的位置。
- 如果可燃氣體在抽濕機週圍積聚，可能引起火災。
- 如果抽濕機在使用過程中被撞翻，請立即關閉裝置，並立即拔下電源線。目視檢查抽濕機確保沒有損壞。如果懷疑抽濕機已損壞，請聯絡技術員或客戶服務尋求幫助。
- 雷雨天氣必須切斷電源，以免雷電損壞抽濕機。
- 不要在地毯下面拉電線。不要用地毯、轉輪或類似的覆蓋物覆蓋電線。不要在傢俱或抽濕機下面佈線。電線宜遠離通行區域和不會被絆倒的地方。
- 勿對抽濕機使用損壞的電線或插頭。廢棄抽濕機或返回給授權的服務機構進行檢修。
- 為了減少火災或觸電的危險，勿將此風扇與任何固態速度控制裝置配合使用。
- 應依照國家接線規定安裝抽濕機。
- 請聯絡授權的維修技術員維修或保養本抽濕機。本產品不用時請關閉電源。

⚠ 注意

- 製造商銘牌位於裝置後面板上，含有本裝置的特定電氣參數和其他技術數據。
- 確保裝置正確接地。為了儘量減少震動和火災風險，重點必須正確接地。電源線配有三叉接地插頭，以防產生電擊危險。
- 使用抽濕機必須連接接地良好的牆壁插座。如果待用牆壁插座未充分接地或沒有延時保險絲或斷路器保護（參閱銘牌了解電氣數據），請安排合格電工安裝適當的插座。
- 不要在潮濕的房間如浴室或洗衣間操作抽濕機。抽濕機電路板（PCB）設計有保險絲提供過流保護。

氟化氣體有關提示（採用 R290 製冷劑的抽濕機不適用）

- 含氟溫室氣體置於密封裝置中。有關含氟溫室氣體的類型、數量和二氧化碳當量（某些機型專有）的具體資訊，請參閱抽濕機本身的相關標籤。
- 本裝置的安裝、服務、維護和檢修必須由認證技術員執行。
- 產品拆卸和回收必須由認證技術員執行。

警告

- 室內不得使用可重複使用的機械接頭和喇叭形接頭。
- 為了安全起見，裝置已配備檢漏系統。為了有效檢漏，裝置必須在安裝後隨時通電，檢修時除外。
- 不要使用加速除霜過程或清潔方法，製造商推介的方法除外。
- 電器儲存的房間內應沒有持續工作火源（例如明火、工作中的燃氣裝置或工作中的電加熱器）。
- 不得出現扎破或燒傷事故。
- 注意製冷劑可能不含異味。







A2L

（產品如果含有 R32 製冷劑，僅限於符合 IEC 60335-2-40:2022 標準）

警告：易燃物料

室內機或室外機上顯示符號的說明

	<p>警告</p>	<p>此符號表示本電器使用易燃冷媒。如果製冷劑泄漏並接觸外部火源，則存在著火風險。</p>
	<p>注意</p>	<p>此符號表示應仔細閱讀操作手冊。</p>
	<p>注意</p>	<p>此符號表示維修人員應參照安裝手冊處理此裝置。</p>
	<p>注意</p>	<p>此符號表示諸如操作手冊或安裝手冊之類的可用資訊。</p>

1. 安裝（空間）

- 管道工件的安裝應儘量簡單易行。
- 保護管道工件不受物理損壞。
- 製冷劑管道應遵守關於氣體的國家法規。
- 機械連接應觸手可及，便於維護。
- 如果需要機械通風，通風開口應保持通暢。
- 使用產品時應根據國家規定妥善處理。

2. 檢修

- 任何參與或中斷制冷劑迴路工作的人員都應持有行業認可的評估機構頒發的當前有效證書，此類機構授權其根據行業認可的評估規範安全處理製冷劑的資質。
- 3. 如果維護和修理作業需要其他熟練人員協助，應在具備易燃製冷劑資質的人員監督下執行。
- 4. 尤其注意不得讓（油、水等）異物進入管道。此外，在儲存管道時，透過擠壓、貼膠帶等方法牢牢密封開口。
- 5. 所有影響安全設施的作業流程只能由具備資質的人員執行。
- 6. 沒有最少房間使用面積要求。
- 7. 電器應當妥善儲存，以防機械損壞。
- 8. 對於管道產品，連接到電器的管道不得包含潛在火源；
- 9. 當透過空氣管道系統連接到一個或多個房間時，送風和迴風應直接通往這些空間。假天花板等開放區域不得用作迴風管道；
- 10. 避免製冷管道過度振動或脈動
- 11. 無論裝置在安裝後處於靜止狀態和運行狀態，或在至少這些靜止或運行條件的壓力下，均應使用製冷劑靈敏度為5克/年或更靈敏的檢測裝置測試接頭。裝置的室內側不得使用可拆卸接頭（可用鈎焊、電焊接頭）。
- 12. 如果使用易燃製冷劑，裝置安裝空間的要求和/或通風要求的決定依據是
 - 電器中使用的電量（M）、
 - 安裝位置、
 - 電器的通風類型或電器類型。
- 13. 只能依照製造商的建議執行檢修。
- 14. 使用易燃製冷劑時，請參閱以下安裝要求。
 - 應儘可能保護防護裝置、管道和配件，以免受到不利環境影響，例如減壓管中有積水和結冰的危險，或積累污垢和殘渣；
 - 應採取預防措施避免製冷管道過度振動或脈動；
 - 製冷系統管道的設計和安裝應儘量減小液壓衝擊損壞系統的可能性；
 - 對於長管道的膨脹和收縮應當作出規定；
 - 管道中應正確放置電磁閥以避免液壓衝擊，且不得堵塞制冷液，除非提供充分泄壓；
 - 鋼制管道和部件應採用防鏽塗層作防腐保護後才能用於任何絕緣。
 - 現場製作的室內製冷管接頭應執行密封性測試。測試方法的靈敏度應為至少在0.25倍最大允許壓力條件下制冷劑泄漏不得高於5克/年。不應檢測到泄漏；
 - 可能產生電弧或火花的電子器件，由於符合22.116.1之要點b)、c)、d)或f)而不被視為火源，只能用電器製造商指定的零件代替。如果用其他零件代替，萬一發生泄漏可能會導致製冷劑着火；
- 15. 通風不良區域
 - 如果裝有易燃製冷劑的電器安裝在通風不良區域，請確保它不會停止運行，從而對任何製冷劑泄漏產生着火或爆炸的風險。
- 16. 工人資格

任何維護、服務和維修操作都要求工作人員具備資質。每一個影響安全措施的工作流程只能由參加培訓並取得勝任資質的合格人員執行，並有證書備檔。此類流程的培訓由國家培訓機構或製造商執行，此類經過認證的機構專門講授立法規定的相關國家資質標準。所有培訓應遵循IEC 60335-2-40:2022版的附件HH的要求。

此類工作流程舉例如下：

- 中斷製冷迴路；
- 開啟密封元件；
- 開啟通風外殼。

檢修資訊

1. 檢查工作區

在開始使用含有易燃製冷劑的系統前，需要執行安全檢查，確保著火風險降至最低。對於製冷系統的維修，在執行此類工作前，應遵守以下預防措施。

2. 工作流程

應在受控流程下開展工作，以儘量減少開展工作時存在易燃氣體或蒸汽的風險。

3. 一般工作區

向在現場工作的所有維修人員和其他人員說明即將開展的工作的性質。避免在密閉空間內工作。

4. 檢查是否有製冷劑

在工作前和工作期間，應使用適當的製冷劑探測器檢查工作區，確保技術人員意識到可能存在易燃氣體。確保當前所用檢漏裝置適用於易燃製冷劑，即無火花、充分密封或本質上安全。

5. 配備滅火器

如果要對製冷裝置或任何相關部件執行任何動火作業，應準備好適當的滅火裝置。在充填區附近配備乾粉滅火器或二氧化碳滅火器。

6. 無火源

任何人執行與製冷系統有關的工作，如涉及接觸任何管道工件，使用任何火源均不得導致著火或爆炸的危險。所有可能的火源，包括吸煙，都應遠離安裝、修理、拆卸和處置地點，因為在此期間製冷劑可能會釋放到週圍空間。在開始工作前，應檢查裝置週圍的區域，確保沒有易燃或着火風險。應出示「嚴禁吸煙」標誌。

7. 通風區

在中斷系統或執行任何動火作業之前，確保工作區域處於開放狀態或通風良好。在開展工作期間，應繼續保持通風良好。釋放的任何製冷劑都應透過通風安全擴散出去，並最好排到大氣中。

8. 檢查製冷裝置

在更換電子器件時，新器件應當合用，並且規格正確。應始終遵循製造商的維護和服務指南。

如有疑問，請諮詢製造商的技術部門尋求幫助。對使用可燃冷媒的裝置應進行以下檢查：

- 製冷劑加注量與安裝含製冷劑裝置的房間大小一致；
- 通風機械和出口工作良好，無阻塞；
- 如果使用間接製冷迴路，應檢查二次迴路是否存在製冷劑；
- 裝置上的標記一直清晰可見，糾正難以辨認的標記和標誌；
- 製冷管或器件的安裝位置不能接觸可能腐蝕容納製冷劑的器件的任何物質，除非器件本身耐腐蝕或由適當的防腐材料製成。

9. 檢查電氣裝置

電子器件的修理和維護應包括初始安全檢查和器件檢查流程。如果存在可能危及安全的故障，則在電路得到令人滿意的處理之前，電源不得接入電路。如果無法立即糾正故障，但需要繼續運行，應使用充分的臨時解決方案。應向裝置所有者報告上述情況，以便告知各方。

初步安全檢查應包括：

- 電容器放電：應以安全的方式進行，避免可能產生火花
- 充填、回收或吹掃系統時，任何帶電的電子器件和電線均未裸露在外；
- 地線連接良好。

10. 密封電子器件

密封的電子器件不得修理。

11. 佈線

檢查電纜，確保不會受到磨損、腐蝕、過壓、振動、銳邊或任何其他不利的環境影響。檢查考慮因素還應包括老化或源於壓縮機或風扇的持續振動的影響。

12. 易燃製冷劑的檢測

在任何情況下均不得使用潛在火源來搜尋或檢測製冷劑泄漏。不得使用鹵化物檢漏燈（或任何其他採用明火的探測器）。

以下檢漏方法對於製冷劑系統是可接受的。電子檢漏器可用於檢測製冷劑泄漏，但如果是易燃製冷劑，靈敏度可能不夠，否則可能需要重新校準。（檢測裝置應在無製冷劑區域進行校準。）

確保探測器不是潛在火源，並且適用於所用製冷劑。檢漏裝置應設置在製冷劑著火下限（LFL）百分比，並根據所用製冷劑校準，確認氣體百分比合適（最大 25%）。

檢漏液也適用於大多數製冷劑，但應避免使用含氯洗滌劑，因為氯可能與製冷劑反應並腐蝕銅管工件。

提示：檢漏液實例如下：

- 氣泡法，
- 熒光劑法。

如果懷疑泄漏，則應清除/熄滅所有明火。

如果發現製冷劑泄漏需要鈔焊，應從系統回收所有製冷劑，或（透過截止閥）在系統遠離泄漏的部分隔離。請參閱以下說明取出製冷劑。

13. 製冷劑排出和迴路清空

因檢修或任何其他目的中斷製冷劑迴路時，應依照常規流程。但是對於易燃製冷劑，必須依照最佳做法，因為必須考慮易燃性這個因素。請遵守以下流程：

- 按照地方和國家法規安全取出製冷劑；
- 排空；
- 用惰性氣體吹掃管路（A2L 型可選）；
- 排空（A2L 型可選）；
- 使用火焰時斷開電路用惰性氣體連續沖掃或吹掃；
- 斷開電路

充填的製冷劑應當回收到正確的回收鋼瓶中。製造商應指定可使用的惰性氣體。不得使用壓縮空氣或氧氣淨化製冷劑系統。

提示：乾燥的氮氣視為一種惰性氣體。

應採用惰性氣體充入系統真空來淨化製冷劑迴路，並繼續充填直到達到工作壓力，然後排放到大氣中，最後降壓到真空。應重複以上過程，直到系統內沒有製冷劑。此系統降低至大氣壓才能正常工作。

確保真空泵的出口不靠近任何潛在火源，並且通風良好。

14. 充填流程

除常規充填流程外，還應遵循以下要求：

- 確保在使用充填裝置時不同製冷劑不會發生污染。軟管或管路應儘可能短，以儘量減少其中所含製冷劑量。
- 鋼瓶應依照說明置於適當位置。
- 向系統充填製冷劑前，確保製冷系統接地。
- 充填完成時標記系統（如果尚未標記）。
- 應特別注意製冷系統不得充填過滿。

重新充填系統前，應透過適當的氣體吹掃完成壓力測試。充填完成時，應對系統執行泄漏測試，然後調試。離開現場前應執行跟蹤泄漏測試。

15. 廢棄

在執行此流程前，技術人員必須完全熟悉裝置及其所有細節。建議採用安全回收所有製冷劑的良好做法。執行任務前，應對機油和製冷劑取樣，以便在重用回收的製冷劑前進行分析。

在任務開始前必須正常供電。

- 熟悉裝置及其操作
- 對系統進行電氣隔離
- 執行流程前確保：
 - 如果需要，可以使機械處理裝置來處理製冷劑鋼瓶；
 - 所有個人防護裝置均配備到位；
 - 回收過程隨時有合適的人員監督；

- 回收裝置和鋼瓶符合適當的標準。
- d) 如果可能，關閉製冷劑系統。
- e) 如果無法完全排空，則製作歧管，以便從系統各部件排出製冷劑。
- f) 回收前務必對鋼瓶秤重。
- g) 啟動回收機並依說明操作。
- h) 鋼瓶不要裝太滿（液體裝入量不超過 80%）。
- i) 不要超過鋼瓶的最大工作壓力，臨時超壓也不允許。
- j) 當鋼瓶正確充填並完成流程時，確保鋼瓶和裝置立即從現場移走，並關閉裝置上的所有隔離閥。
- k) 回收的製冷劑除非經過清潔和檢查，不得裝入另一個製冷系統。

16. 標籤

裝置應貼上標籤，說明其已廢棄，並清空製冷劑。標籤應註明日期並簽名。對於含有易燃製冷劑的電器，確保裝置上有標籤，說明裝置含有易燃製冷劑。

17. 回收

從系統中排出製冷劑時，無論是檢修還是廢棄，均要妥善處理，以便安全排出所有製冷劑。轉移製冷劑到鋼瓶中時，確保僅使用適當的製冷劑回收鋼瓶。確保有足夠數量的鋼瓶容納全部製冷劑。指定所有鋼瓶都用於回收製冷劑，並為其貼上標籤（即製冷劑回收專用鋼瓶）。鋼瓶應配有減壓閥和相關的截止閥，且工況良好。清空回收鋼瓶，如果可能，冷卻後進行回收。回收裝置應處於良好工況，並隨附裝置說明書，且適合回收易燃製冷劑。如有疑問，請諮詢製造商。此外，請配備一套校準的稱重秤，並處於良好工況。軟管配備的斷開接頭應無泄漏且處於良好工況。

根據當地法律，回收的製冷劑應採用合適的回收鋼瓶處理，並附上相關的廢物轉運說明。不要在回收裝置中混合製冷劑，尤其不要在鋼瓶中混裝。

如果要拆卸壓縮機或排出壓縮機油，請確保先排空到可接受的液位，確保潤滑劑中不會殘留易燃製冷劑。不得用明火或其他火源加熱壓縮機本體來加速上述過程。從系統排油應安全進行。

18. 裝置的運輸、標記和儲存

1. 遵守運輸法規運輸含有易燃製冷劑的裝置。
2. 遵守當地法規使用標誌標記裝置。
3. 遵守國家法規處置採用易燃製冷劑的裝置。
4. 裝置/家電的儲存應遵循製造商的說明儲存裝置。
5. 包裝（未售出）裝置的儲存

儲存包裝保護的構造應確保包裝內裝置的機械損壞不會導致製冷劑充填泄漏。

允許裝置一起存放的最大數量由當地法規決定

了解產品

部件識別

注

手冊中的所有插圖僅用於解釋含義。您的機器可能略有不同。具體情況以實際形狀為準。透過控制面板可控制抽濕機。

產品概述

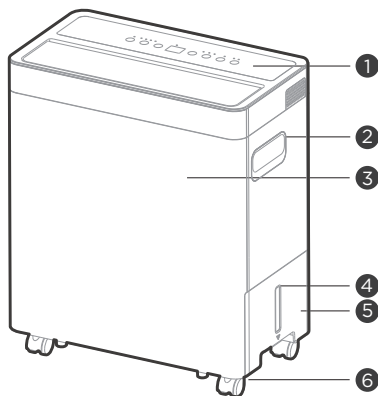

前視圖

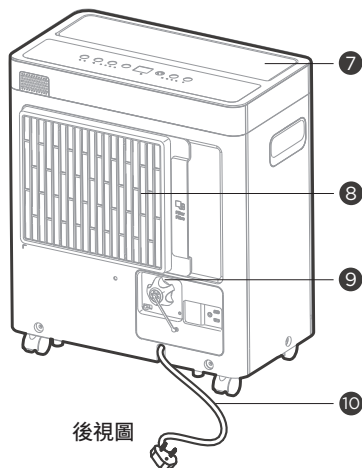

後視圖

- | | | | |
|---|--------|---|-------------|
| ① | 控制面板 | ⑥ | 腳輪 |
| ② | 把手（兩側） | ⑦ | 出風格柵 |
| ③ | 前面板 | ⑧ | 空氣過濾器（進氣格柵） |
| ④ | 液位窗 | ⑨ | 連續排水軟管出口 |
| ⑤ | 水桶 | ⑩ | 電源線和插頭 |

設計通知

為確保公司產品的最佳性能，設備設計規範如有更改，恕不另行通知。

定位裝置

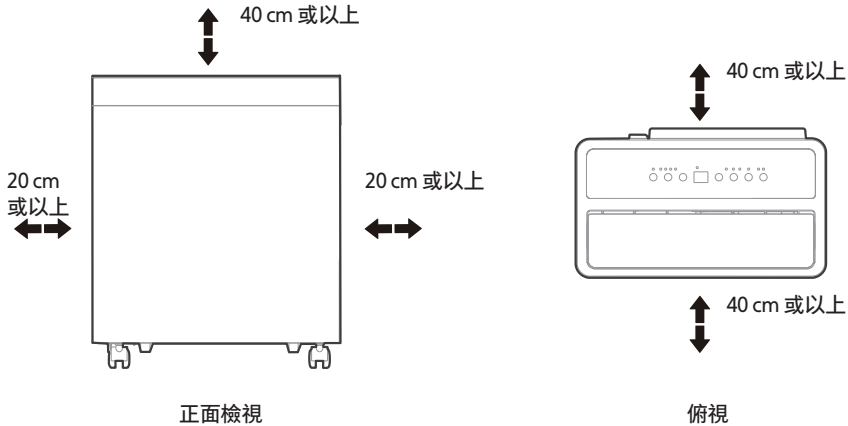

腳輪（裝置底部四點）

- 腳輪可自由移動。
- 不要強迫腳輪在地毯上移動，也不要將桶內有水的情況下移動裝置。（裝置可能會翻倒導致水溢出）

在地下室工作的抽濕機對相鄰的封閉式儲存區域（如壁櫥）幾乎沒有乾燥效果，除非有充分的空氣流通進入該區域。

- 不要在戶外使用。
- 這款抽濕機僅供住宅室內專用。
- 這款抽濕機不適合商業或工業應用。
- 抽濕機放置在足夠承受裝置和一滿桶水重量的平滑地板上。
- 抽濕機兩側至少有 20 cm 空間，確保通風良好。（出風口至少有 40 cm 空間）
- 裝置放置區域的溫度不低於 5 °C (41 °F)。盤管表面在溫度低於 5 °C (41 °F) 時可能會結霜，從而降低性能。
- 裝置要遠離烘乾機、加熱器或散熱器。
- 在儲存書籍或貴重物品的任何地方使用裝置防止受潮損壞。
- 在地下室使用抽濕機，以防受潮。
抽濕機必須在封閉區域工作才能最有效。
- 執行一切傾斜和搬移操作前取出水桶，開啟連續排水口清空水，並斷開電源線。

使用產品時

注

桶內水位達到一定程度時，請小心移動機器，以免掉落。

第一次使用

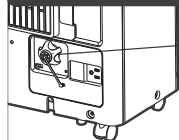

確保水蓋安裝牢固，且 24 小時持續工作。

工作條件要求

最小值	工作溫度	最大值
5 °C/41 °F		32 °C/90 °F
最小值	工作溫度	最大值
30% (RH)		80% (RH)

使用注意事項



快速重啟後，等待 3 分鐘恢復正常工作。

正確連接電源

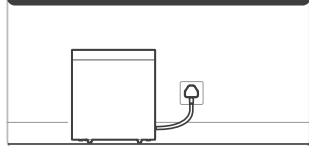

接地連接

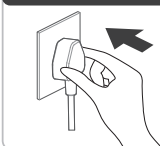

*請以實際插頭為準，圖例僅供參考。

正確安裝水箱

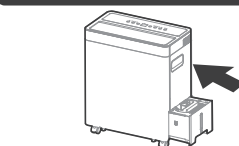

- 首次使用抽濕機時，請連續 24 小時運行裝置。確保在連續除濕模式下，塑料蓋安裝牢固，且不會出現洩漏。
- 裝置設計的工作環境溫度介於 5 °C/41 °F 至 32 °C/90 °F，相對濕度介於 30% 至 80% 之間。
- 在開窗的開放空間使用時，產品表面可能形成冷凝，這是正常情況。
- 如果裝置已關機，需要快速重新開機，請留出大約三分鐘時間恢復正常運行。
- 不要連接抽濕機到多孔插座上，因為其他電器也在使用此插座。
- 選擇合適的位置，確保便於接入電源插座。
- 裝置應插入帶接地的電源插座。
- 確保水桶安裝正確，否則裝置將無法正常工作。

附件

配件

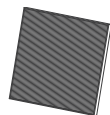

HEPA 過濾器 (1 件)

可選配件



排水軟管 (1 件*)

提示：使用時拉直水管。

了解功能

控制面板功能

注

以下控制面板僅用於解釋含義。您購買的裝置的控制面板可能會隨機型略有不同。您的抽濕機可能不含某些指示燈或按鈕。具體情況以實際形狀為準。

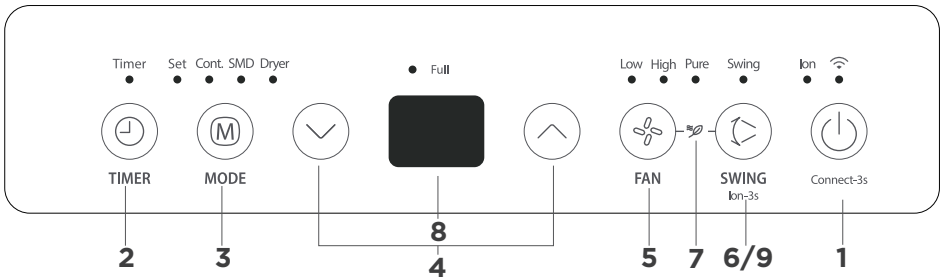

1. 電源開/關按鈕

按下可開啟和關閉抽濕機。

無線按鈕（某些機型專有）

1. 按住「電源」按鈕 3 秒鐘可啟動無線連接模式。LED 顯示屏顯示「AP」，表示您可以設置無線連接，無線指示燈閃爍。
2. 如果 8 分鐘內連接（路由器）成功，抽濕機將自動退出無線連接模式，無線指示燈亮起，裝置進入上一功能。如果在 8 分鐘內連接失敗，則抽濕機自動退出無線連接模式。

2. 定時器功能

按下此按鈕結合「向上」和「向下」按鈕可啟動自動開機和自動停機功能。

自動開機設置

1. 在關機狀態下，按下此按鈕激活自動開機時間。
2. 按下或長按「向上」或「向下」按鈕可將自動開機時間更改為按 0.5 小時遞增，直到 10 小時，然後以 1 小時遞增，直到 24 小時。
3. 所選時間將在 5 秒內記錄，系統將自動恢復顯示濕度。此控制設置將倒計時直到剩餘時間，直到開機。

自動停止設置

1. 在啟動狀態下，按下此按鈕激活自動停機時間。
2. 按下或長按「向上」或「向下」按鈕可更改自動停止時間按 0.5 小時遞增，直到 10 小時，然後按 1 小時遞增，直到 24 小時。
3. 所選時間將在 5 秒內記錄，系統將自動恢復顯示濕度。此控制設置將倒計時剩餘時間，直到停止。

注

定時可以調節為按 24 小時增減。定時器設置完成後，您可以再次按下此按鈕檢查定時器設置狀態。定時器設置完成後，您可以透過將設置時間設置為 0.0 來取消此設置。

3. 模式功能

按下此按鈕選擇您想要的模式，如圖所示：設置→連續→SMD→乾燥

注

在「烘乾機」、「連續」和「SMD」模式下無法調整濕度設置；設定「設置」模式時會顯示設定的濕度，5 秒後顯示環境濕度。

設置除濕模式（設置）

按下此按鈕選擇「除濕」模式，並透過按下「向上」和「向下」按鈕調整所需的濕度。

注

濕度可從 35% 設置到 85%，每次按壓可調節 5%。

連續除濕模式（連續）

按下此按鈕選擇連續除濕模式。

注

此模式下無法調節濕度。

按壓擺動裝置調整並固定出風口的位置。

智能除濕模式（SMD）

按下此按鈕選擇智能除濕模式。

注

此模式下無法調節濕度。本機會根據室溫自動控制房間濕度在 45% ~ 55% 的舒適範圍內。

烘乾機模式（烘乾機）

按下此按鈕選擇烘乾機模式，在此模式下，機器將以連續除濕和高速風扇方式運行。

1. 在此模式下工作時，請關閉門窗。
2. 為了最有效除濕，先使濕衣服脫水。
3. 確保氣流引向濕衣服。
4. 對於厚重的濕衣服，可能無法獲得最佳除濕效果。

注

在烘乾機模式下無法調節濕度和風速。

按壓擺動裝置調整並固定出風口的位置。

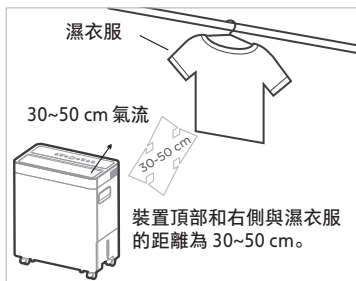

4. 向上和向下按鈕

濕度設置控制按鈕

濕度水平可以設置相對濕度在 35% RH 到 85% RH 的範圍內，增量為 5%。

定時器設置控制按鈕

按「向上」和「向下」按鈕設置自動開始和自動停止時間範圍為從 00:00 到 24:00。

5. 風扇調速功能

按下此按鈕在以下設置中選擇風扇速度：低 → 高 → 低...

注

風扇轉速指示燈在不同的風扇轉速設置下亮起。

6. 擺動功能

按下此按鈕可開啟或關閉「擺動」功能。

7. 淨化功能

開啟或關閉電源時，短按「風扇」按鈕和「擺動」按鈕進入淨化功能，顯示屏顯示「ON」約3秒後，將自動啟動淨化功能，並同時停止抽濕功能。

8. 顯示屏

顯示環境濕度和設置濕度（濕度範圍：30% 至 90%）；

顯示「定時器」設置（定時範圍：24 小時）；

顯示錯誤代碼提醒。

錯誤代碼	可能原因	解決辦法
EH61	蒸發器盤管溫度感應器出錯。	拔下裝置並重新插入。如果錯誤重複出現，請聯絡製造商、其服務代理或有類似資質的人員尋求服務。
EH60	室溫感應器出錯。	
EH00	室內 EEPROM 出錯。	
EH0b	顯示面板通訊出錯。	
P2	水桶裝滿水或水桶位置不對。	清空桶並換到正確位置。

9. ION 功能（某些機型專有）

在啟動狀態下，長按「擺動」按鈕 3 秒可開啟 ION 功能。

注

每次啟動後，負離子功能也按預設開啟。

更多功能

自動關機

當水桶裝滿時，或者取出水桶時，或者水桶沒有歸位時，抽濕機會關機。對於某些機型，風扇電機將繼續運行 30 秒。水滿指示燈亮起時，請清空水桶並歸位，另一個問題是正確安裝水桶。然後，等待 3 分鐘再恢復運行，前 3 分鐘不能重啟。這是為了保護裝置。3 分鐘後將自動開始運行。

自動重啟

如果裝置因斷電而意外中斷運行，當電源恢復時，它將自動以以前的功能設置重啟。

傾倒積水

有兩種方法可以排出積水。

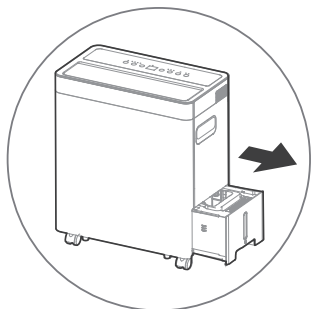

類型 1:

水桶排水

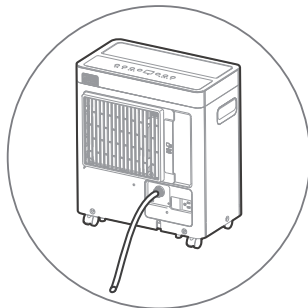

類型 2:

水管排水
(連續)

水桶排水 (類型 1)

- 裝置停止運行時，如果水桶已滿，則水滿指示燈會亮起。
- 裝置運行時，如果水桶已滿，則壓縮機和風扇停止運行，水滿指示燈亮起，數碼屏顯示 P2。
- 水桶拉出一半，然後上拉把手，慢慢垂直提起水桶，防止飛濺。
- 把水倒掉，使水桶復位。水桶必須放在正確的位置，並牢牢固定在抽濕機上才能運行。
- 當水桶放置到正確位置時，裝置才會重啟。

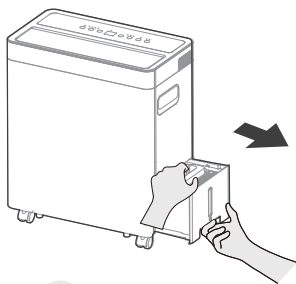

1

水桶拉出一半。

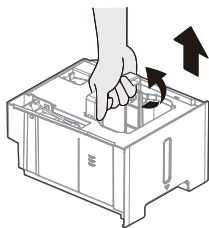

2

上提把手，
慢慢垂直提起水桶。

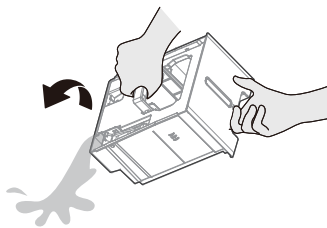

3

把水倒出來。

注

不要拉出整個水桶，否則會損壞水桶，甚至使你受傷。

注

- 取出水桶時，不得觸摸裝置內部的任何部件。因為這樣做可能損壞產品。水桶務必輕輕一直推入到裝置中。水桶撞擊任何東西或未能安全推入可能會導致裝置無法運行。
- 如果裝置中有一些水，取出水桶時，則必須進行乾燥。
- 裝置運行時，如果取出水桶，則壓縮機和風扇停止運行，然後裝置將發出 8 次嗶嗶聲，數碼屏顯示 Eb。
- 裝置停止運行時，如果取出水桶，裝置將發出 8 次嗶嗶聲，數碼屏顯示 Eb。

水管排水（連續）（類型 2）

透過將裝置水管（ID \geq Φ 5/16"，不含）連接到含有內螺紋端（ID：M=1"，不含），水流可以自動排空到地漏。

注

某些機型含有內螺紋端。

從機器後排水口取下水蓋並放在一邊，然後將排水管穿過機器排水口插入排水管，並將排水管引至地漏或合適的排水設施。

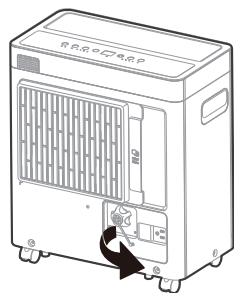

1

拆下水蓋。

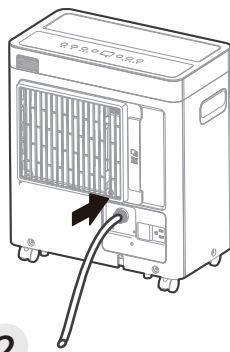

2

連接排水軟管。

- 取下塑料蓋時，如果裝置的後排水口有一些水，必須擦乾。確保軟管牢固，不會產生泄漏，軟管末端水平或向下，讓水順暢流動。
- 引導軟管至排水管，確保無扭結阻止水流。確保水管低於裝置的排水管出口。
- 在裝置上選擇所需的濕度設置和風扇速度，以便持續排水。

注

不使用連續排水功能時，從出口拆下排水軟管，並擦乾連續排水軟管出口。

保養與維修

抽濕機的護理和清潔——在清潔前使抽濕機斷電，從牆壁插座上取下插頭。

清潔格柵和外殼

- 加入清水和柔性清潔劑。勿使用漂白劑或研磨劑。
- 水不要直接濺到主機上。這樣做可能會導致電擊，導致絕緣層退化，或引起裝置生鏽。
- 進氣口和出氣口格柵容易弄髒，所以使用真空配件或刷子清潔。

清潔水桶

- 每隔幾週清潔水桶，以防生長各類細菌。桶中裝入部分清水，加入少量柔性清潔劑。在桶裏來回晃動，沖洗後倒掉。

注

無用洗碗機清洗水桶。清潔後，水桶必須就位並固定牢固，以便抽濕機運行。

清潔空氣過濾器

前格柵後面的空氣過濾器應至少每兩週檢查和清潔一次，必要時更頻繁。

取出方法：

- 按下空氣過濾器上的拉環並向外拉，然後取出。
- 用溫肥皂水清潔空氣過濾器。在更換之前沖洗並讓過濾器乾燥。

安裝方法：

- 如圖所示卸下空氣過濾器（進氣格柵），安裝HEPA過濾器，然後重新裝入機器。
- 建議每6個月更換一次HEPA過濾器。

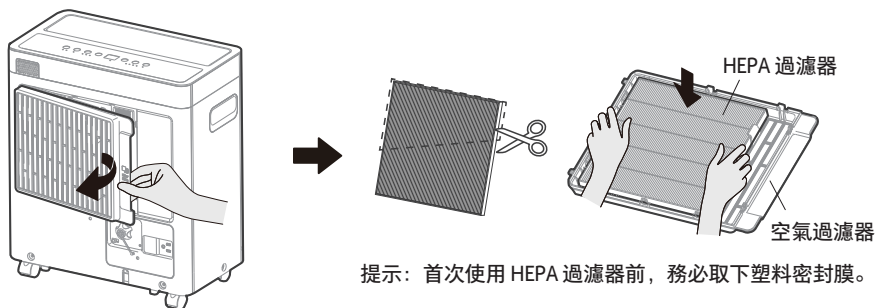

注

請勿沖洗空氣過濾器或放入自動洗碗機中。

長期不用機器時

有關第 4-6 步的說明，請參閱「保養與維修」。

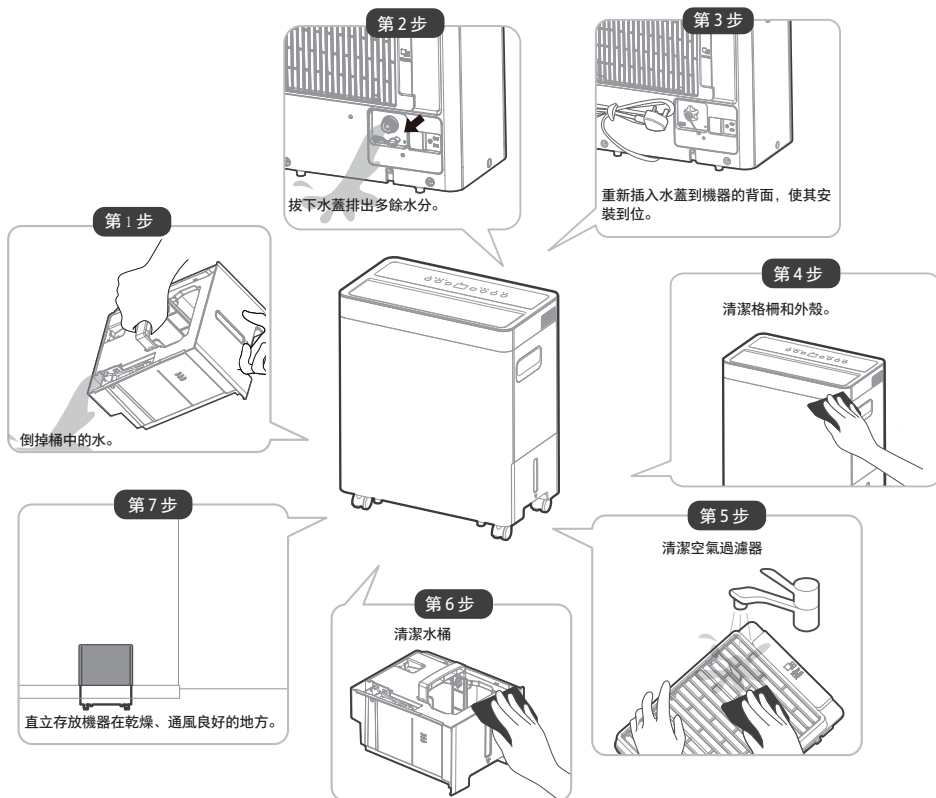

- 清潔主機、水桶和空氣過濾器。
- 卸下水桶後擦乾可能存在的多餘水分。
- 關閉機器後，等待一天再清空水桶，收集使用後可能進一步形成的冷凝水。
- 用電源線扎帶扎緊電線。
- 正確儲存水桶，豎直放置機器。
- 用塑料袋蓋住機器。
- 直立存放機器在乾燥、通風良好的地方。

故障排除

問題	檢查內容
機器未啟動	確保抽濕機插頭完全推入插座。 檢查房屋保險絲/斷路器盒。 抽濕機已達到其當前液位或水桶已滿。 水桶未安裝到位。
抽濕機不按預期乾燥空氣	預留除濕時間不夠。 確保抽濕機的正面或背面無窗簾、百葉窗或傢俱阻擋。 濕度控制設定值不夠低。 檢查所有門窗和其他開口是否關牢。 室溫太低，低於 5 °C (41 °F)。 房間裏有煤油加熱器或散發水蒸氣的東西。
機器工作時噪音大	空氣過濾器堵塞。 機器傾斜放置，本應直立。 地板表面不平。
盤管上出現結霜	這種情況很正常。抽濕機具有自動除霜功能。
地板積水	軟管接頭或軟管連線可能鬆動。 打算用水桶取水，但是後部排水蓋被拔出。
顯示屏中出現 EH00、EH60、EH61、P2	這些是錯誤代碼和保護代碼。 請參閱《了解功能》章節。
壓縮機不工作	壓縮機每連續工作 8 小時，停機 10 分鐘。

設計和規格如有變更，恕不另行通知產品改進。

欲知詳情，請諮詢銷售代理或製造商。手冊的任何更新都將上載到服務網站，請檢查獲取最新版本。

6. 產品廢棄處理

正確處理該產品：

這種標誌表示在整個歐盟中，這種產品不宜與其他家庭垃圾一起處理。為避免因為不受控制的垃圾處理而對境或人身健康造成潛在傷害，回收垃圾以促進材料資料的可持續重複利用。要想回收用過的設備，請使用回收或收集系統或聯繫產品零售商。他們可以確保該產品回收環保安全。





#DetailsMatter

USER MANUAL

Inverter Compressor 2 in 1
Air Purifying Dehumidifier

RAD-DA11HK-1
RAD-DA13HK

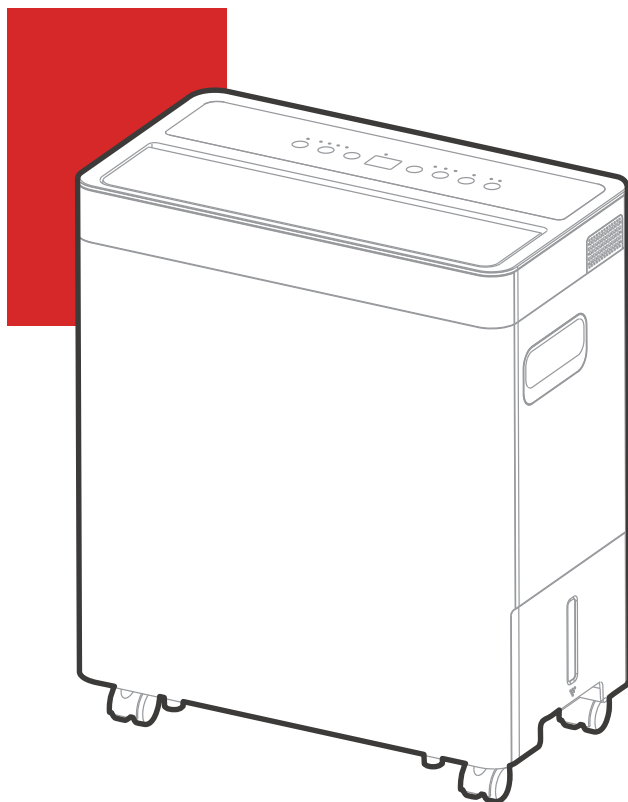

Warning notices: Before using this product,
please read this manual carefully and keep
it for future reference.

TOSHIBA

SAFETY PRECAUTIONS.....3

GET TO KNOW YOUR PRODUCT.....12

Identification of parts

Positioning the unit

When using your product

GET TO KNOW YOUR FEATURES.....15

Control Panel Features

DUMP THE COLLECTED WATER.....18

Bucket drainage (Type 1)

Water hose drainage (continuous) (Type 2)

CARE AND MAINTENANCE.....20

Clean the Grille and Case

Clean the bucket

Clean the air filter

When not using the unit for long time periods

TROUBLESHOOTING.....22

SAFETY PRECAUTIONS

It's really important you read Safety Precautions Before Operation and Installation Incorrect installation due to ignoring instructions can cause serious damage or injury. The seriousness of potential damage or injuries is classified as either a WARNING or CAUTION.

Explanation of Symbols

WARNING

The signal word indicates a hazard with a high level of risk which, if not avoided, may result in serious injury or death.

CAUTION

The signal word indicates a hazard with a low degree of risk which, if not avoided, may result in minor or moderate injury.

Read these operating instructions carefully and attentively before using/commissioning the unit and keep them in the immediate vicinity of the installation site or unit for later use!

WARNING

- Do not exceed the rating of the power outlet or connection device.
- Do not operate or stop the unit by switching on or off the power.
- Do not damage or use an unspecified power cord.
- Do not modify power cord length or share the outlet with other appliances.
- Do not insert or pull out plug with wet hands.
- Do not install the appliance in a location that may be exposed to combustible gas.
- Do not place the unit near a heat source.
- Disconnect the power if strange sounds, smell, or smoke comes from it.
- You should never try to take apart or repair the unit by yourself.
- Before cleaning, turn off the power and unplug the unit.
- Do not use the machine near flammable gas or combustibles, such as gasoline, benzene, thinner, etc.
- Do not drink or use the water drained from the unit.
- **Do not** take the water bucket out during operation.
- Do not put in places where water may splash onto the unit. Place the unit on a level, sturdy section of the floor.
- Do not cover the intake or exhaust openings with cloths or towels.
- Care should be taken when using the unit in a room with the following persons: infants, children, elderly people, and people not sensitive to humidity.
- Do not use in areas where chemicals are handled.
- Never insert your finger or other foreign objects into grills or openings. Take special care to warn children of these dangers.
- Do not place heavy object on the power cord and take care so that the cord is not compressed.
- Do not climb up on or sit on the unit.
- Always insert the air filters securely. Clean air filter once every two weeks.
- If water enters the unit, turn the unit off and disconnect the power, contact a qualified service technician.
- Do not place flower vases or other water container on top of the unit.
- Do not use extension cords.

 **CAUTION**

- This appliance can be used by children aged from 8 years and above and person with reduced physical, sensory or mental capabilities or lack of experience and knowledge if they have been given supervision or instruction concerning use of the appliance in a safe way and understand the hazards involved. Children shall not play with the appliance. Cleaning and user maintenance shall not be made by children without supervision. (be applicable for the European Countries)
- This appliance is not intended for use by persons (including children) with reduced physical, sensory or mental capabilities or lack of experience and knowledge, unless they have been given supervision or instruction concerning use of the appliance by a person responsible for their safety. Children should be supervised to ensure that they do not play with the appliance. (be applicable for other countries except the European Countries)
- If the supply cord is damaged, it must be replaced by the manufacturer, its service agent or similarly qualified persons in order to avoid a hazard.
- Prior to cleaning or other maintenance, the appliance must be disconnected from the supply mains.
- Do not install the appliance in a location that may be exposed to combustible gas.
- If combustible gas accumulates around the unit, it may cause fire.
- If the appliance is knocked over during use, turn off the unit and unplug it from the main power supply immediately. Visually inspect the unit to ensure there is no damage. If you suspect the unit has been damaged, contact a technician or customer service for assistance.
- In a thunderstorm, the power must be cut off to avoid damage to the machine due to lightning.
- Do not run cord under carpeting. Do not cover cord with throw rugs, runners, or similar coverings. Do not route cord under furniture or appliances. Arrange cord away from traffic area and where it will not be tripped over.
- Do not operate unit with a damaged cord or plug. Discard unit or return to an authorized service facility for examination and/or repair.
- To reduce the risk of fire or electric shock, do not use this fan with any solid-state speed control device.
- The appliance shall be installed in accordance with national wiring regulations.
- Contact the authorized service technician for repair or maintenance of this unit. Turn off the product when not in use.

 **CAUTION**

- The manufacturer's nameplate is located on the rear panel of the unit and contains electrical and other technical data specific to this unit.
- Be sure the unit is properly grounded. To minimize shock and fire hazards, proper grounding is important. The power cord is equipped with a three-prong grounding plug for protection against shock hazards.
- Your unit must be used in a properly grounded wall receptacle. If the wall receptacle you intend to use is not adequately grounded or protected by a time delay fuse or circuit breaker (please refer to the nameplate for the electrical data), have a qualified electrician install the proper receptacle.
- Do not operate your appliance in a wet room such as a bathroom or laundry room. The unit's circuit board (PCB) is designed with a fuse to provide overcurrent protection.

Note about Fluorinated Gasses (Not applicable to the unit using R290 Refrigerant)

- Fluorinated greenhouse gases are contained in hermetically sealed equipment. For specific information on the type, the amount and the CO2 equivalent in tones of the fluorinated greenhouse gas (on some models), please refer to the relevant label on the unit itself.
- Installation, service, maintenance and repair of this unit must be performed by a certified technician.
- Product uninstallation and recycling must be performed by a certified technician.

! WARNING

- Reusable mechanical connectors and flared joints are not allowed indoors.
- This unit is equipped with a leak detection system for safety. For leak detection to be effective, the unit must be electrically powered at all times after installation, other than when servicing.
- Do not use means to accelerate the defrosting process or to clean, other than those recommended by the manufacturer.
- The appliance shall be stored in a room without continuously operating ignition sources (for example: open flames, an operating gas appliance or an operating electric heater).
- Do not pierce or burn.
- Be aware that refrigerants might not contain an odor.







A2L

(For products containing R32 refrigerant comply with the IEC 60335-2-40:2022 standard only)

WARNING: FLAMMABLE MATERIAL

Explanation of symbols displayed on the indoor unit or outdoor unit

	<p>WARNING</p>	<p>This symbol shows that this appliance used a flammable refrigerant. If the refrigerant is leaked and exposed to an external ignition source, there is a risk of fire.</p>
	<p>CAUTION</p>	<p>This symbol shows that the operation manual should be read carefully.</p>

	<p>CAUTION</p>	<p>This symbol shows that a service personnel should be handling this equipment with reference to the installation manual.</p>
	<p>CAUTION</p>	<p>This symbol shows that information is available such as the operating manual or installation manual.</p>

1. Installation (Space)

- That the installation of pipe-work shall be kept to a minimum.
- That pipe-work shall be protected from physical damage.
- Where refrigerant pipes shall be compliance with national gas regulations.
- That mechanical connections shall be accessible for maintenance purposes.
- In cases that require mechanical ventilation, ventilation openings shall be kept clear of obstruction.
- When disposing of the product is used, be based on national regulations, properly processed.

2. Servicing

- Any person who is involved with working on or breaking into a refrigerant circuit should hold a current valid certificate from an industry-accredited assessment authority, which authorizes their competence to handle refrigerants safely in accordance with an industry recognized assessment specification.

3. Maintenance and repair requiring the assistance of other skilled personnel shall be carried out under the supervision of the person competent in the use of flammable refrigerants.

4. Be more careful that foreign matter (oil, water, etc.) does not enter the piping.

- Also, when storing the piping, securely seal the opening by pinching, taping, etc.

5. All working procedure that affects safety means shall only be carried by competent persons.

6.No minimum room area requirement.

7. The appliance shall be stored so as to prevent mechanical damage from occurring.

8. For ducted products, the ducts connected to an appliance shall not contain a potential ignition source;

9. When connected via an air duct system to one or more rooms, the supply and return air shall be directly ducted to the space. Open areas such as false ceilings shall not be used as a return air duct;

10. Avoid excessive vibration or pulsation to refrigerating piping

11. Joints shall be tested with detection equipment with a capability of 5g/year of refrigerant or better, with the equipment in standstill and under operation or under a pressure of at least these standstill or operation conditions after installation. Detachable joints shall NOT be used in the indoor side of the unit (brazed, welded joint could be used).

12. When a FLAMMABLE REFRIGERANT is used, the requirements for installation space of appliance and/or ventilation requirements are determined according to

- The mass charge amount (M) used in the appliance,
- The installation location,
- The type of ventilation of the location or of the appliance.

13. Servicing shall be performed only as recommended by the manufacturer.

-
14. When a FLAMMABLE REFRIGERANT is used, see the following requirements for installation
- That protection devices, piping, and fittings shall be protected as far as possible against adverse environmental effects, for example, the danger of water collecting and freezing in relief pipes or the accumulation of dirt and debris;
 - That precautions shall be taken to avoid excessive vibration or pulsation to refrigerating piping;
 - That piping in refrigeration systems shall be so designed and installed to minimize the likelihood of hydraulic shock damaging the system;
 - That provision shall be made for expansion and contraction of long runs of piping;
 - That solenoid valves shall be correctly positioned in the piping to avoid hydraulic shock and shall not block in liquid refrigerant unless adequate relief is provided;
 - Steel pipes and components shall be protected against corrosion with a rustproof coating before applying any insulation
 - Field-made refrigerant joints indoors shall be tightness tested. The test method shall have a sensitivity of 5 grams per year of refrigerant or better under a pressure of at least 0, 25 times the maximum allowable pressure.
No leak shall be detected;
 - Electrical components that can arc or spark, which are not considered ignition sources due to compliance with 22.116.1 points b), c), d), or f) shall only be replaced with parts specified by the appliance manufacturer.
Replacement with other parts may result in the ignition of refrigerant in the event of a leak;
15. Unventilated areas
- For appliances containing flammable refrigerants is installed in an unventilated area, please make sure that it will not stagnate so as to create a fire or explosion hazard for any refrigerant leak.
16. Qualification of workers
- Any maintenance, service and repair operations must be required qualification of the working personnel. Every working procedure that affects safety means shall only be carried out by competent persons that joined the training and achieved competence should be documented by a certificate. The training of these procedures is carried out by national training organizations or manufacturers that are accredited to teach the relevant national competency standards that may be set in legislation. All training shall follow the ANNEX HH requirements of IEC 60335-2-40:2022 Edition. Examples for such working procedures are:
- Breaking into the refrigerating circuit;
 - Opening of sealed components;
 - Opening of ventilated enclosures.

Information on servicing

1. Checks to the area

Prior to beginning work on systems containing flammable refrigerants, safety checks are necessary to ensure that the risk of ignition is minimized. For repair to the refrigerating system, the following precautions shall be complied with prior to conducting work on the system.

2. Work procedure

Works shall be undertaken under a controlled procedure so as to minimize the risk of a flammable gas or vapor being present while the work is being performed.

3. General work area

All maintenance staff and others working in the local area shall be instructed on the nature of work being carried out. Work in confined spaces shall be avoided.

4. Checking for presence of refrigerant

The area shall be checked with an appropriate refrigerant detector prior to and during work, to ensure the technician is aware of potentially flammable atmospheres. Ensure that the leak detection equipment being used is suitable for use with flammable refrigerants, i.e., no sparking, adequately sealed or intrinsically safe.

5. Presence of fire extinguisher

If any hot work is to be conducted on the refrigeration equipment or any associated parts, appropriate fire extinguishing equipment shall be available to hand. Have a dry power or CO2 fire extinguisher adjacent to the charging area.

6. No ignition sources

No person carrying out work in relation to a REFRIGERATING SYSTEM which involves exposing any pipe work shall use any sources of ignition in such a manner that it may lead to the risk of fire or explosion. All possible ignition sources, including cigarette smoking, should be kept sufficiently far away from the site of installation, repairing, removing and disposal, during which refrigerant can possibly be released to the surrounding space. Prior to work taking place, the area around the equipment is to be surveyed to make sure that there are no flammable hazards or ignition risks. "No Smoking" signs shall be displayed.

7. Ventilated area

Ensure that the area is in the open or that it is adequately ventilated before breaking into the system or conducting any hot work. A degree of ventilation shall continue during the period that the work is carried out. The ventilation should safely disperse any released refrigerant and preferably expel it externally into the atmosphere.

8. Checks to the refrigerating equipment

Where electrical components are being changed, they shall be fit for the purpose and to the correct specification. At all times the manufacturer's maintenance and service guidelines shall be followed. If in doubt consult the manufacturer's technical department for assistance. The following checks shall be applied to installations using FLAMMABLE REFRIGERANTS:

- the refrigerant charge is in accordance with the room size within which the refrigerant containing parts are installed;
- the ventilation machinery and outlets are operating adequately and are not obstructed;
- if an indirect refrigerating circuit is being used, the secondary circuits shall be checked for the presence of refrigerant;
- marking to the equipment continues to be visible and legible, marking and signs that are illegible shall be corrected;
- refrigerating pipe or components are installed in a position where they are unlikely to be exposed to any substance which may corrode refrigerant containing components, unless the components are constructed of materials which are inherently resistant to being corroded or are suitably protected against being so corroded.

9. Checks to electrical devices

Repair and maintenance to electrical components shall include initial safety checks and component inspection procedures. If a fault exists that could compromise safety, then no electrical supply shall be connected to the circuit until it is satisfactorily dealt with. If the fault cannot be corrected immediately but it is necessary to continue operation, an adequate temporary solution shall be used. This shall be reported to the owner of the equipment so all parties are advised.

Initial safety checks shall include:

- That capacitors are discharged: this shall be done in a safe manner to avoid possibility of sparking
- That there are no live electrical components and wiring are exposed while charging, recovering or purging the system;
- That there is continuity of earth bonding.

10. Sealed electrical components

Sealed electrical components shall not be repaired.

11. Cabling

Check that cabling will not be subject to wear, corrosion, excessive pressure, vibration, sharp edges or any other adverse environmental effects. The check shall also take into account the effects of aging or continual vibration from sources such as compressors or fans.

12. Detection of flammable refrigerants

Under no circumstances shall potential sources of ignition be used in the searching for or detection of refrigerant leaks. A halide torch (or any other detector using a naked flame) shall not be used. The following leak detection methods are deemed acceptable for refrigerant systems. Electronic leak detectors may be used to detect refrigerant leaks but, in the case of FLAMMABLE REFRIGERANTS, the sensitivity may not be adequate, or may need re-calibration. (Detection equipment shall be calibrated in a refrigerant-free area.) Ensure that the detector is not a potential source of ignition and is suitable for the refrigerant used. Leak detection equipment shall be set at a percentage of the LFL of the refrigerant and shall be calibrated to the refrigerant employed, and the appropriate percentage of gas (25% maximum) is confirmed.

Leak detection fluids are also suitable for use with most refrigerants but the use of detergents containing chlorine shall be avoided as the chlorine may react with the refrigerant and corrode the copper pipe-work.

NOTE Examples of leak detection fluids are

- Bubble method,
- Fluorescent method agents.

If a leak is suspected, all naked flames shall be removed/extinguished.

If a leakage of refrigerant is found which requires brazing, all of the refrigerant shall be recovered from the system, or isolated (by means of shut of valves) in a part of the system remote from the leak. See the following instructions of removal of refrigerant.

13. Refrigerant removal and circuit evacuation

When breaking into the refrigerant circuit to make repairs - or for any other purpose conventional procedures shall be used. However, for flammable refrigerants it is important that best practice be followed, since flammability is a consideration. The following procedure shall be adhered to:

- Safely remove refrigerant following local and national regulations;
- Evacuate;
- Purge the circuit with inert gas (optional for A2L);
- Evacuate (optional for A2L);
- Continuously flush or purge with inert gas when using flame to open circuit; and
- open the circuit

The refrigerant charge shall be recovered into the correct recovery cylinders. The manufacturer shall specify the inert gases that can be used. Compressed air or oxygen shall not be used for purging refrigerant systems.

NOTE an example of an inert gas is dry nitrogen.

Purging of the refrigerant circuit shall be achieved by breaking the vacuum in the system with inert gas and continuing to fill until the working pressure is achieved, then venting to atmosphere, and finally pulling down to a vacuum. This process shall be repeated until no refrigerant is within the system. The system shall be vented down to atmospheric pressure to enable work to take place. Ensure that the outlet of the vacuum pump is not close to any potential ignition sources and that ventilation is available.

14. Charging procedures

In addition to conventional charging procedures, the following requirements shall be followed:

- Ensure that contamination of different refrigerants does not occur when using charging equipment. Hoses or lines shall be as short as possible to minimize the amount of refrigerant contained in them.
- Cylinders shall be kept in an appropriate position according to the instructions.
- Ensure that the refrigerating system is earthed prior to charging the system with refrigerant.
- Label the system when charging is complete (if not already labelled).
- Extreme care shall be taken not to overfill the refrigerating system.

Prior to recharging the system, it shall be pressure-tested with the appropriate purging gas. The system shall be leak-tested on completion of charging but prior to commissioning. A follow up leak test shall be carried out prior to leaving the site.

15. Decommissioning

Before carrying out this procedure, it is essential that the technician is completely familiar with the equipment and all its detail. It is recommended good practice that all refrigerants are recovered safely. Prior to the task being carried out, an oil and refrigerant sample shall be taken in case analysis is required prior to re-use of recovered refrigerant. It is essential that electrical power is available before the task is commenced.

- a) Become familiar with the equipment and its operation.
- b) Isolate system electrically
- c) Before attempting the procedure ensure that:
 - Mechanical handling equipment is available, if required, for handling refrigerant cylinders;
 - All personal protective equipment is available and being used correctly;
 - The recovery process is supervised at all times by a competent person;
 - Recovery equipment and cylinders conform to the appropriate standards.
- d) Pump down refrigerant system, if possible.
- e) If a vacuum is not possible, make a manifold so that refrigerant can be removed from various parts of the system.
- f) Make sure that cylinder is situated on the scales before recovery takes place.
- g) Start the recovery machine and operate in accordance with instructions.
- h) Do not overfill cylinders (no more than 80% volume liquid charge).
- i) Do not exceed the maximum working pressure of the cylinder, even temporarily.
- j) When the cylinders have been filled correctly and the process completed, make sure that the cylinders and the equipment are removed from site promptly and all isolation valves on the equipment are closed of.
- k) Recovered refrigerant shall not be charged into another refrigerating system unless it has been cleaned and checked.

16. Labelling

Equipment shall be labelled stating that it has been de-commissioned and emptied of refrigerant. The label shall be dated and signed. For appliances containing **flammable refrigerants**, ensure that there are labels on the equipment stating the equipment contains **flammable refrigerant**.

17. Recovery

When removing refrigerant from a system, either for servicing or decommissioning, it is required to follow good practice so that all refrigerants are removed safely.

When transferring refrigerant into cylinders, ensure that only appropriate refrigerant recovery cylinders are employed. Ensure that the correct number of cylinders for holding the total system charge is available. All cylinders to be used are designated for the recovered refrigerant and labelled for that refrigerant (i.e., special cylinders for the recovery of refrigerant). Cylinders shall be complete with pressure-relief valve and associated shut-off valves in good working order. Empty recovery cylinders are evacuated and, if possible, cooled before recovery occurs.

The recovery equipment shall be in good working order with a set of instructions concerning the equipment that is at hand and shall be suitable for the recovery of the flammable refrigerant. Consult manufacturer if in doubt. In addition, a set of calibrated weighing scales shall be available and in good working order. Hoses shall be complete with leak-free disconnect couplings and in good condition.

The recovered refrigerant shall be processed according to local legislation in the correct recovery cylinder, and the relevant waste transfer note arranged. Do not mix refrigerants in recovery units and especially not in cylinders.

If compressors or compressor oils are to be removed, ensure that they have been evacuated to an acceptable level to make certain that flammable refrigerant does not remain within the lubricant. The compressor body shall not be heated by an open flame or other ignition sources to accelerate this process. Draining of oil from a system shall be carried out safely.

18. Transportation, marking and storage for units

1. Transport of equipment containing flammable refrigerants Compliance with the transport regulations.
2. Marking of equipment using signs Compliance with local regulations.
3. Disposal of equipment using flammable refrigerants Compliance with national regulations.

4. Storage of equipment/appliances

The storage of equipment should be in accordance with the manufacturer's instructions.

5. Storage of packed (unsold) equipment

Storage package protection should be constructed such that mechanical damage to the equipment inside the package will not cause a leak of the refrigerant charge.

The maximum number of pieces of equipment permitted to be stored together will be determined by local regulations.

GET TO KNOW YOUR PRODUCT

Identification of parts

NOTE

All the illustrations in the manual are for explanation purpose only. Your machine may be slightly different. The actual shape shall prevail. The unit can be controlled by the unit control panel.

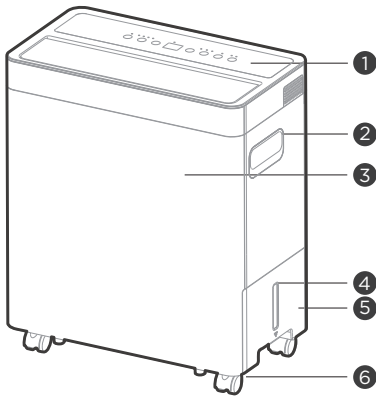

Front View

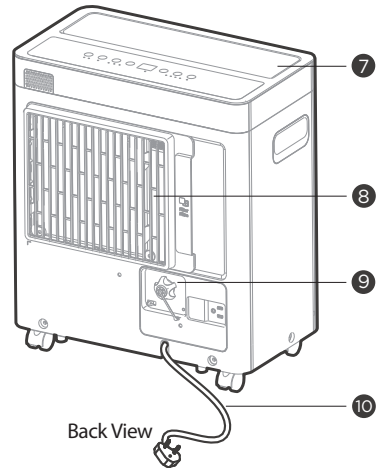

Back View

- | | | | |
|---|---------------------|---|-------------------------------|
| ① | Control panel | ⑥ | Caster |
| ② | Handle (both sides) | ⑦ | Air outlet grille |
| ③ | Front panel | ⑧ | Air filter (Air inlet grille) |
| ④ | Water level window | ⑨ | Continuous drain hose outlet |
| ⑤ | Water bucket | ⑩ | Power cord and plug |

Design Notice

In order to ensure the optimal performance of our products, the design specifications of the unit are subject to change without prior notice.

Positioning the unit

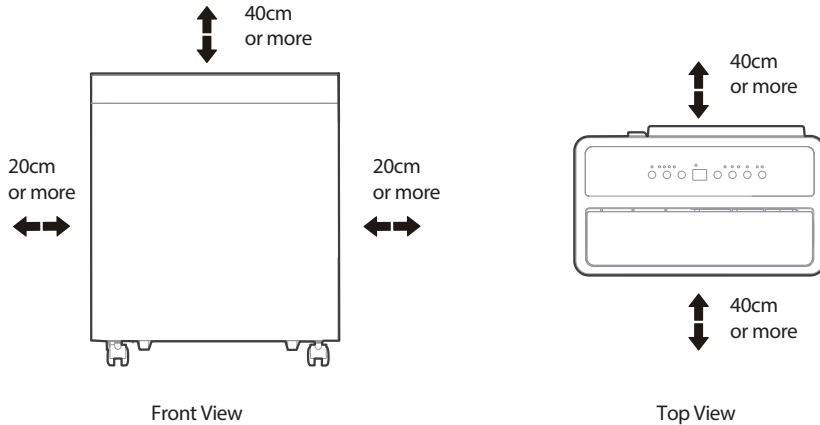

Casters (At four points on the bottom of unit)

- Casters can move freely.
- Do not force casters to move over carpet, nor move the unit with water in the bucket. (The unit may tip over and spill water)

A dehumidifier operating in a basement will have little or no effect in drying an adjacent enclosed storage area, such as a closet, unless there is adequate circulation of air in and out of the area.

- Do not use outdoors.
- This dehumidifier is intended for indoor residential applications only.
- This dehumidifier should not be used for commercial or industrial applications.
- Place the dehumidifier on a smooth, level floor strong enough to support the unit with a full bucket of water.
- Allow at least 20cm of air space on all sides of the unit for good air circulation. (at least 40cm of air space on air outlet)
- Place the unit in an area where the temperature will not fall below 5° C (41° F). The coils can become covered with frost at temperatures below 5° C (41° F), which may reduce performance.
- Place the unit away from the clothes dryer, heater or radiator.
- Use the unit to prevent moisture damage anywhere books or valuables are stored.
- Use the dehumidifier in a basement to help prevent moisture damage. The dehumidifier must be operated in an enclosed area to be most effective.
- Before all tilting and moving operations, take out the bucket, open the continuous drain outlet to empty the water, and disconnect the power cord.

When using your product

NOTE

When the water in the bucket reaches to a certain level, please be careful to move the machine to avoid it falling down.

First time using



Ensure the drain cover is securely installed and operate the unit continuously 24 hours.

Working condition requirement

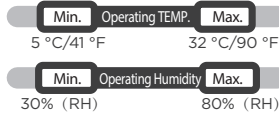

Precautions for use



After a quick restart, wait 3 minutes for the operation to resume.

Correct power connection

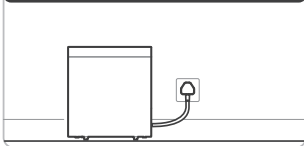

Earth connection

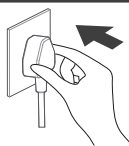

*Please refer to the actual plug, and the legend is for reference only.

Proper installation of water tank

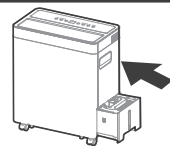

- When first using the dehumidifier, operate the unit continuously 24 hours. Ensure that the plastic cover is securely installed in continuous dehumidification mode and does not leak.
- This unit is designed to operate with a working environment between 5 °C/41 °F and 32 °C/90 °F, and between 30%(RH) and 80%(RH).
- When use in open space with open windows, condensation may form on the surface of the product, which is normal.
- If the unit has been switched of and needs to be switched on again quickly, allow approximately three minutes for the correct operation to resume.
- Do not connect the dehumidifier to a multiple socket outlet, which is also being used for other electrical appliances.
- Select a suitable location, making sure you have easy access to an electrical outlet.
- Plug the unit into an electrical socket-outlet with earth connection.
- Make sure the Water bucket is correctly fitted otherwise the unit will not operate properly.

Accessories

Accessories

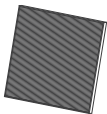

HEPA filter (1 pc)

Optional accessories



Drain Hose (1 pc*)

NOTE: Make the water pipe straight when you use it.

GET TO KNOW YOUR FEATURES

Control Panel Features

NOTE

The following control panels are for explanation purpose only. The control panel of the unit you purchased may be slightly different according to the models. Your machine may not contain some indicators or buttons. The actual shape shall prevail.

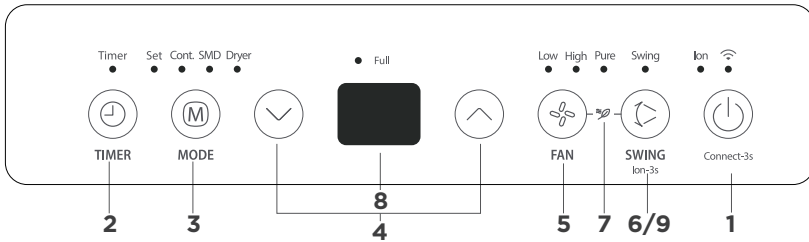

1. POWER ON/OFF button

Press to turn the dehumidifier on and off.

Wireless button (on some models)

1. Press and hold on the POWER button for 3 seconds to initiate the Wireless connection mode. The LED DISPLAY shows "AP" to indicate you can set Wireless connection and the wireless indicator light flashes.
2. If connection (router) is successful within 8 minutes, the unit will exit Wireless connection mode automatically and the Wireless indicator illuminates and the unit enters the previous function. If connection is failure within 8 minutes, the unit exits the Wireless connection mode automatically.

2. TIMER Function

Press the button to initiate the Auto start and Auto stop function, in conjunction with the UP and DOWN buttons.

Auto start setting

1. In the shutdown state, press the button to active the Auto start time.
2. Press or hold the UP or DOWN button to change the Auto start time by 0.5 hour increments, up to 10 hours, then at 1 hour increments, up to 24 hours.
3. The selected time will register in 5 seconds and the system will automatically revert back to display the humidity. The control will count down the time remaining until start.

Auto stop setting

1. In the startup state, press the button to active the Auto stop time.
2. Press or hold the UP or DOWN button to change the Auto stop time by 0.5 hour increments, up to 10 hours, then at 1 hour increments, up to 24 hours.
3. The selected time will register in 5 seconds and the system will automatically revert back to display the humidity. The control will count down the time remaining until start.

NOTE

The timing can be adjusted to increase or decrease by 24 hours. After the TIMER setting is complete, you can press the button again to check the TIMER setting status. After the TIMER setting is complete, you can cancel it by setting the set time to 0.0.

3. MODE Function

Press the button to select the mode you want, as shown: Set → Cont. → SMD → Dryer

NOTE

The humidity setting cannot be adjusted in Dryer, Cont. and SMD; The set humidity will be displayed when the mode is set to Set, and the ambient humidity will be displayed 5 seconds later.

Set Dehumidifying mode (Set)

Press the button to select the Dehumidifying mode, and adjust the desired humidity by pressing the UP and DOWN buttons.

NOTE

Humidity can be set from 35% to 85%, with 5% adjustment per press.

Continuous dehumidifying mode (Cont.)

Press the button to select the Continuous dehumidifying mode.

NOTE

Humidity cannot be adjusted in this mode.

Press the SWING to adjust and fixing the position of air outlet grille.

Smart Dehumidification mode (SMD)

Press the button to select the Smart dehumidification mode.

NOTE

Humidity cannot be adjusted in this mode. The unit will automatically control room humidity in a comfortable range 45%~55% according to the room temperature.

Dryer mode (Dryer)

Press the button to select the Dryer mode, and the unit will operate in Continuous dehumidifying and High fan speed mode, in this mode.

1. Close doors and Windows while operating in this mode.
2. To make the best effective dehumidification, please dehydrate the wet clothes at first.
3. Make sure to direct airflow at the wet clothes.
4. For thick and heavy wet clothes may not get the best effective dehumidification.

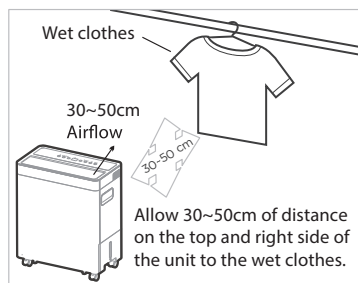

NOTE

Humidity and wind speed cannot be adjusted in Dryer mode.

Press the SWING to adjust and fixing the position of air outlet grille.

4. UP and DOWN buttons

Humidity Set Control buttons

The humidity level can be set within a range of 35% RH (Relative Humidity) to 85%RH(Relative Humidity) in 5% increments.

TIMER Set Control buttons

Press the UP and DOWN buttons to set the Auto start and Auto stop time from 00:00 to 24:00.

5. FAN speed Function

Press the button to select fan speed in the following setting: Low → High → Low...

NOTE

The fan speed indicator light illuminates under different fan speed settings.

6. SWING Function

Press the button to turn the Swing function on or off.

7. PURIFICATION Function

When the power is turned on or off, short press the FAN button and SWING button to enter the purification function, when the display shows 'ON' for about 3 seconds, the purification function automatically starts, and the dehumidifying function stops.

8. DISPLAY

Display ambient humidity and setting humidity (humidity range: 30% to 90%);

Display TIMER setting (timing range: 24 hours);

Display error codes reminder.

Error codes	Possible Causes	Solution
EH61	Evaporator coil temperature sensor error.	Unplug the unit and plug it back in. If the error repeats, Contact the manufacturer, its service agents or a similar qualified person for service.
EH60	Room temperature sensor error.	
EH00	Indoor EEPROM error.	
EH0b	Display panel communication error.	
P2	Bucket is full of water or bucket is not in right position.	Empty the bucket and replace it in the right position.

9. ION Function (on some models)

In the startup state, press the SWING button for 3 seconds to turn on the ION function.

NOTE

After each startup, the negative ion function is also turned on by default.

More Features

Auto Shut Off

The dehumidifier shuts off when the bucket is full, or when the bucket is removed or not replaced in the proper position. For some models, the fan motor will continue to run for 30 seconds. When the Full indicator light illuminates, please empty the bucket and reinstall it correctly, and the other problems are to install the bucket correctly. Then, wait 3 minutes before resuming operation, it cannot be restarted operation in the first 3 minutes. This is to protect the unit. Operation will automatically start after 3 minutes.

Auto-Restart

If the unit breaks off unexpectedly due to the power cut, it will restart with the previous function setting automatically when the power resumes.

DUMP THE COLLECTED WATER

There are two ways to remove collected water.

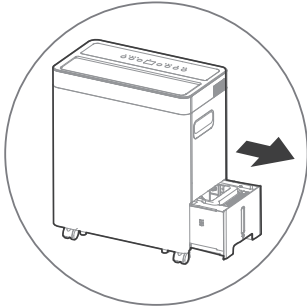

Type 1:

Bucket drainage

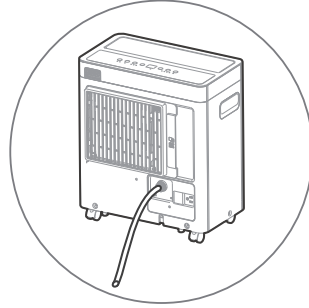

Type 2:

**Water hose drainage
(continuous)**

Bucket drainage (Type 1)

- When the unit is off, if the bucket is full, the Full indicator light will light.
- When the unit is on, if the bucket is full, the compressor and the fan turn off, and the Full indicator light will light, the digital display shows P2.
- Pull the bucket out halfway, then pull up the handle and lift the bucket slowly vertically to prevent spatter.
- Throw away the water and replace the bucket. The bucket must be in right place and securely seated for the dehumidifier to operate.
- The appliance will re-start when the bucket is restored in its correct position.

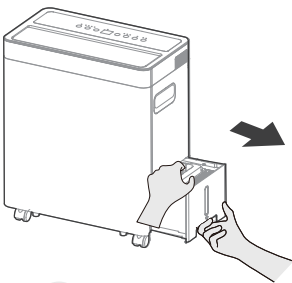

1

**Pull the bucket out
halfway.**

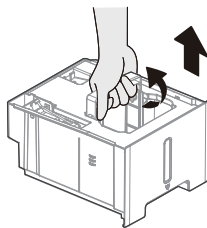

2

**Pull up the handle
and lift the bucket
slowly vertically.**

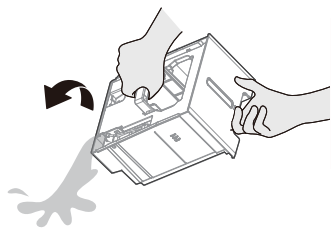

3

Pour the water out.

NOTE

Do not pull out the whole bucket, or it may cause damage to the bucket or even injure you.

NOTE

- When you remove the bucket, do not touch any parts inside of the unit. Doing so may damage the product. Be sure to push the bucket gently all the way into the unit. Banging the bucket against anything or failing to push it in securely may cause the unit not to operate.
- When you remove the bucket, if there is some water in the unit you must dry it.
- When the unit is on, if the bucket is removed, the compressor and the fan turn off, then the unit will beep 8 times and the digital display shows Eb.
- When the unit is off, if the bucket is removed, the unit will beep 8 times and the digital display shows Eb.

Water hose drainage (continuous) (Type 2)

Water can be automatically emptied into a floor drain by attaching the unit with a water hose (Id \geq Φ5/16", not included) with a female threaded end (ID:M=1",not included)

NOTE

On some models, the female threaded end is included.

Remove the drain cover from the back drain outlet of the unit and set aside, then insert the drain hose through the drain outlet of the unit and lead the drain hose to the floor drain or a suitable drainage facility.

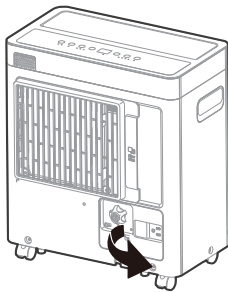

1

Remove the drain cover.

- When you remove the plastic cover, if there is some water in the back drain outlet of the unit you must dry it. Make sure the hose is secure so there are no leaks and the end of the hose is level or down to let the water flow smoothly.
- Direct the hose toward the drain, making sure that there are no kinks that will stop the water flowing. Make sure the water hose is lower than the drain hose outlet of the unit.
- Select the desired humidity setting and fan speed on the unit for continuous draining to start.

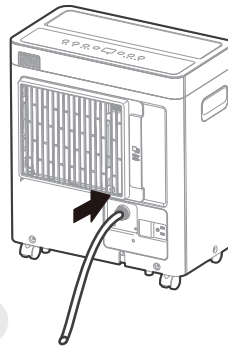

2

Connect the drain hose.

NOTE

When the continuous draining feature is not being used, remove the drain hose from the outlet, and dry the water in the continuous drain hose outlet.

CARE AND MAINTENANCE

Care and cleaning of the dehumidifier turn the dehumidifier off and remove the plug from the wall outlet before cleaning.

Clean the Grille and Case

- Use water and a mild detergent. Do not use bleach or abrasives.
- Do not splash water directly onto the main unit. Doing so may cause an electrical shock, cause the insulation to deteriorate, or cause the unit to rust.
- The air intake and outlet grilles get soiled easily, so use a vacuum attachment or brush to clean.

Clean the bucket

- Every few weeks, clean the bucket to prevent growth of mold, mildew and bacteria. Partially fill the bucket with clean water and add a little mild detergent. Swish it around in the bucket, empty and rinse.

NOTE

Do not use a dishwasher to clean the bucket. After clean, the bucket must be in place and securely seated for the dehumidifier to operate.

Clean the air filter

The air filter behind the front grille should be checked and cleaned at least every two weeks or more often if necessary.

To remove:

- Press down the tab on the air filter and pull it outward, then take it out.
- Clean the air filter with warm, soapy water. Rinse and let the filter dry before replacing it.

To attach:

- Disassemble the air filter (air intake grille) as shown, assemble the HEPA filter, and then reinstall it into the machine.
- HEPA filter is recommended to be replaced once every 6 months.

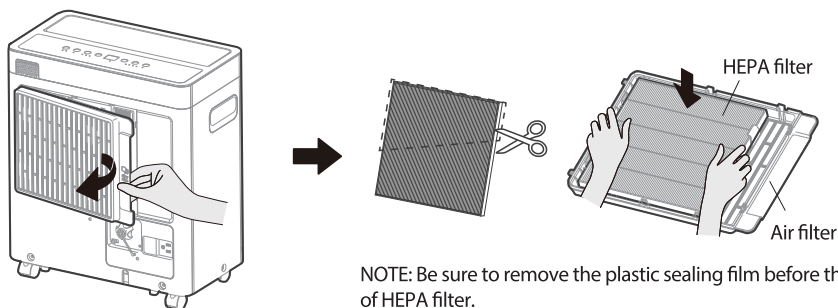

NOTE: Be sure to remove the plastic sealing film before the first use of HEPA filter.

NOTE

DO NOT RINSE OR PUT THE AIR FILTER IN AN AUTOMATIC DISHWASHER.

When not using the unit for long time periods

Refer to Care and Maintenance for instruction on steps 4-6.

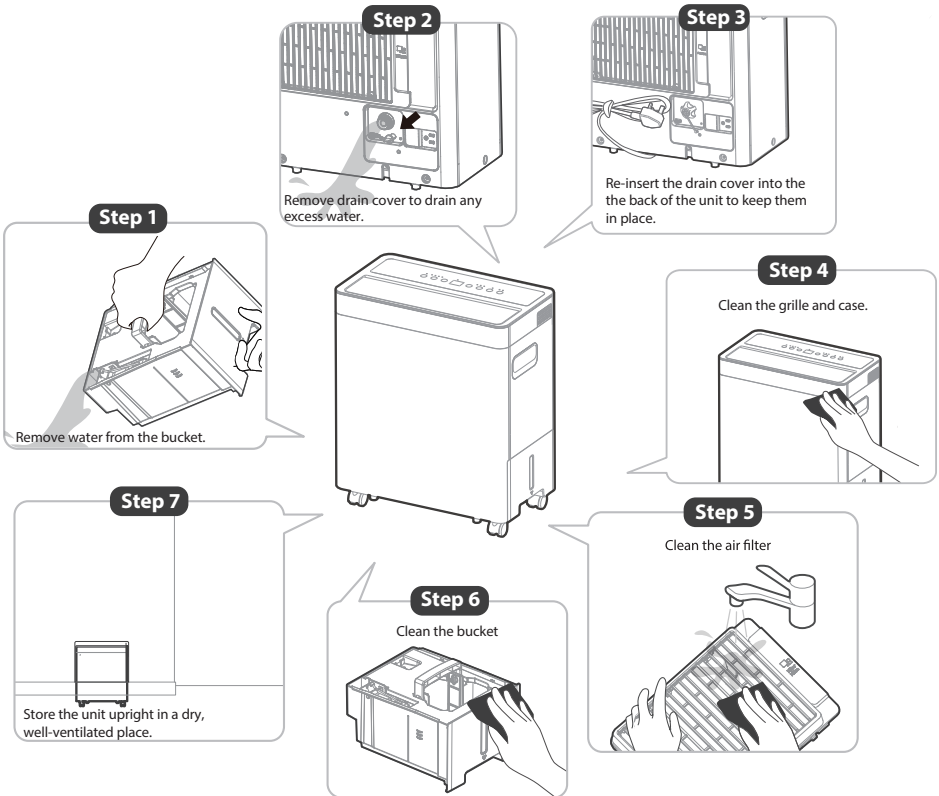

- Clean the main unit, water bucket and air filter.
- Please dry off any excess water that may be present after removing the bucket.
- After turning of the unit, wait one day before emptying the bucket to collect any condensate that may continue to form after use.
- Wrap the cord with the power cord buckle.
- Properly restore the bucket and place the unit in an upright position.
- Cover the unit with a plastic bag.
- Store the unit upright in a dry, well-ventilated place.

TROUBLESHOOTING

Problem	What to check
Unit does not start	Make sure the dehumidifier's plug is pushed completely into the outlet. Check the house fuse/circuit breaker box. Dehumidifier has reached its present level or bucket is full. Water bucket is not in the proper position.
Dehumidifier does not dry the air as it should	Do not allow enough time to remove the moisture. Make sure there are no curtains, blinds or furniture blocking the front or back of the dehumidifier. The humidity control may not be set low enough. Check that all doors, windows and other openings are securely closed. Room temperature is too low, below 5°C(41°F). There is a kerosene heater or something giving off water vapor in the room.
The unit makes a loud noise when operating	The air filter is clogged. The unit is tilted instead of upright as it should be. The floor surface is not level.
Frost appears on the coils	This is normal. The dehumidifier has Auto defrost feature.
Water on floor	Hose to connector or hose connection may be loose. Intend to use the bucket to collect water, but the back drain cover is removed.
EH00,EH60,EH61,P2 appear in the display	These are error codes and protection codes. See the GET TO KNOW YOUR FEATURES section.
The compressor has stopped working	Whenever the compressor runs continuously for 8 hours, stop it for 10 minutes.

The design and specifications are subject to change without prior notice for product improvement. Consult with the sales agency or manufacturer for details. Any updates to the manual will be uploaded to the service website, please check for the latest version.

6. Disposal of your appliance

Correct Disposal of this product: This marking indicates that this product should not be disposed with other household wastes throughout the EU. To prevent possible harm to the environment or human health from uncontrolled waste disposal, recycle it responsibly to promote the sustainable reuse of material resources. To return your used device, please use the return and collection system or contact the retailer where the product was purchased. They can take this product for environmental safe recycling









#DetailsMatter