

# TOSHIBA

**蒸氣焗爐**  
MS2-TQ20SC(BK)  
**快速入門指南**  
**SteamOven**  
**Quick Owner's Manual**

使用前請仔細閱讀本手冊，並妥善保管

本資料上所有內容均經過認真核對，如有任何印刷錯漏或內容上的誤解，可向本公司諮詢。  
注：產品若有技術改進，會編進新版手冊中，恕不另行通知。產品外觀、顏色如有改動，以實物為準。

# 目錄

產品簡介	第 3 頁
初次使用	第 4 頁
水盒使用	第 5 頁
控制面板	第 6 頁
操作流程	第 7 頁
自動功能表	第 11 頁
溫馨提示	第 13 頁
服務指南	第 14 頁

# CONTENT

Product Introduction	15
Initial Use	16
Use of Water Box	17
Control Panel	18
Operating Process	19
Auto Menu Setting	23
Tips	25
Service Guide	26

# 產品簡介

## ⚠ 備註

- 如實物與下圖存在差異，請以實物為準
- 請參考圖示中標記的安全距離擺放產品
- 此產品為桌面式產品，禁止用作嵌入式

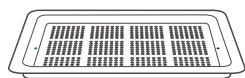
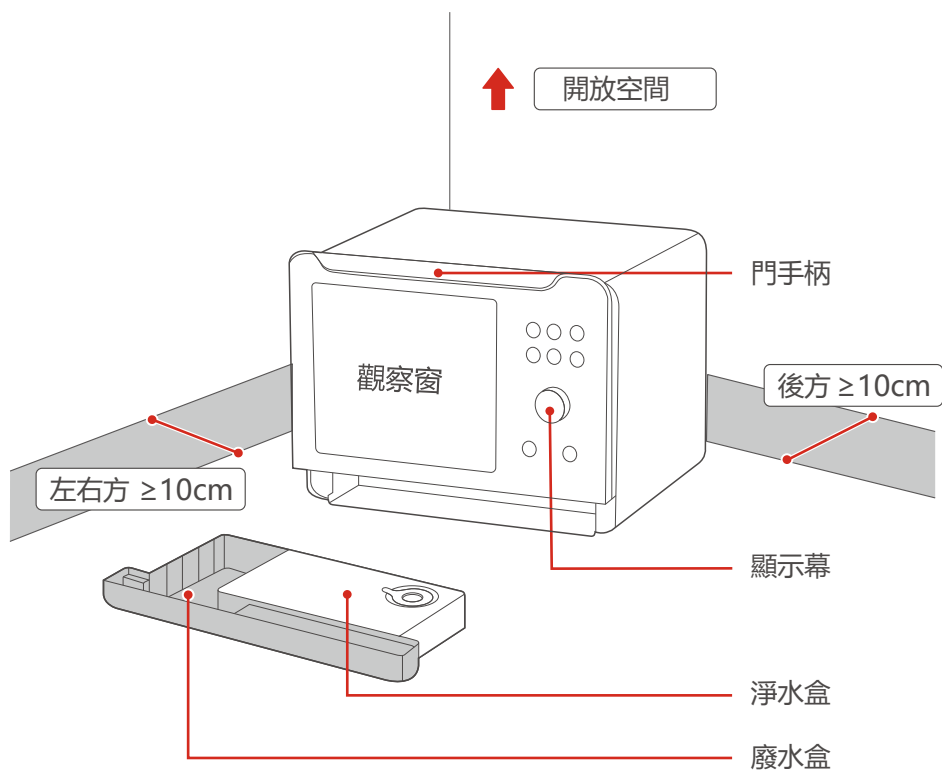

**蒸盤**  
(只適用於蒸功能)



**烤盤**  
(只適用於焗功能)  
(使用時請鋪上錫紙)

# 初次使用

1. 關上爐門，請勿放置任何物件於爐內

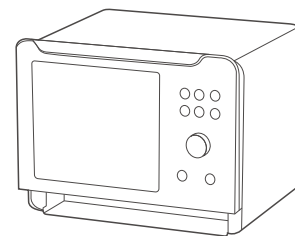

2. 將水箱加滿，按  鍵，扭動按鈕選擇「36 爐腔清潔」



3. 按  鍵開始清潔，時間約需10分鐘





4. 清潔完成時，蜂鳴器會發出一下聲響，然後請打開爐門進行冷卻

- a. 清潔完成後，請勿馬上用手觸碰爐腔
- b. 冷卻後請用柔軟抹布清潔爐腔
- c. 徹底冷卻前，請勿關閉爐門

# 水盒使用

## ⚠ 注意

- 水盒缺水時，水泵會發出類似蜂鳴的提示音，提示機器缺水，此時請及時將水盒加滿水；若水盒一直處於缺水狀態，蜂鳴30秒鐘後，機器會暫停工作，並每隔三秒發出【叮叮叮叮叮】提示音，同時螢幕顯示【】及“FILL”。請將水盒加水至“MAX”線，並按  繼續烹調。

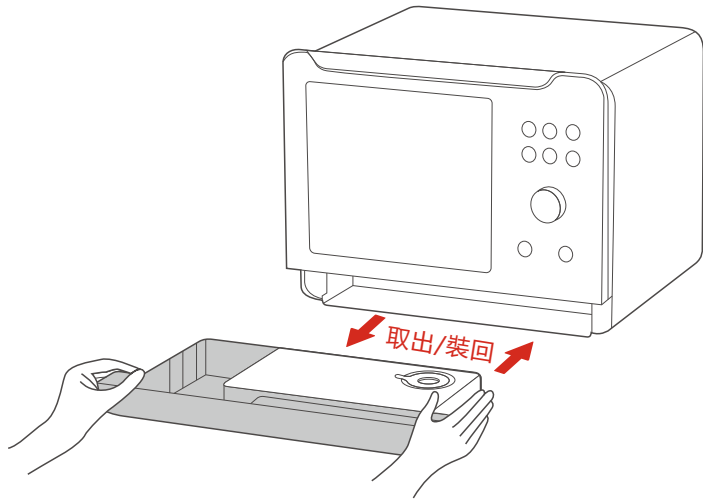

- 水盒加入凍開水，以免產生水垢影響機器使用壽命
- 烹飪後須將廢水盒及淨水盒內的水倒掉以免滋生細菌

### 加水方法

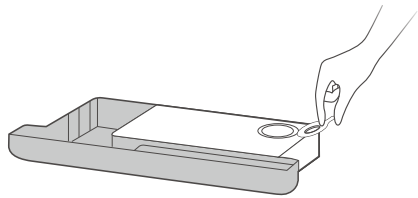

揭開膠圈後加入適量凍開水，蓋上膠圈，確保貼合完好

### 清潔方法

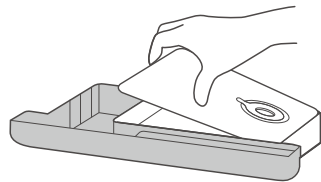

揭開水盒蓋可進行清潔，或倒掉剩餘的水

# 控制面板

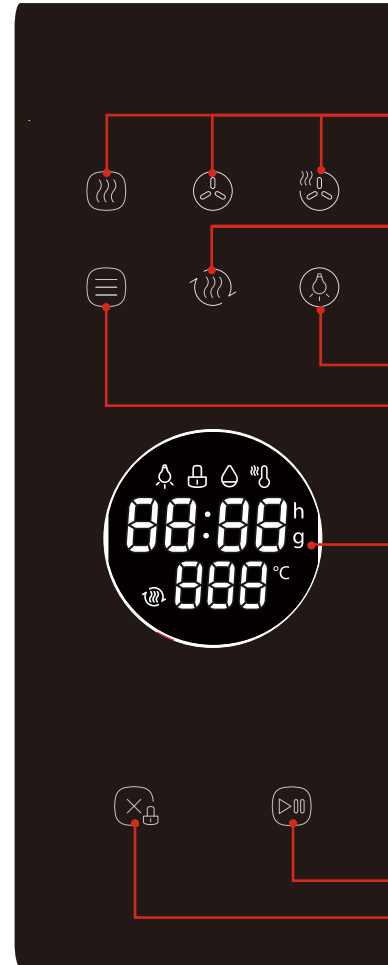

功能

爐內燈  
自動菜單

【顯示屏/確定】

旋轉選擇  
· 時間  
· 溫度  
· 自動功能

【開始/暫停】  
【取消/兒童鎖】

 爐內燈   
  兒童鎖   
  水盒缺水   
  爐溫過高   
  預熱   
 h 小時   
 g 自動功能食物重量   
 °C 溫度(攝氏)

# 操作流程

## ! 備註

- 按爐內燈  鍵可打開/關閉爐燈，隨時能觀察爐腔內的食物情況
- 使用所有蒸煮/蒸氣烤焗/發酵模式，請先把水盒加滿水

- 完成烹調時，蒸爐會發出提示音，請取出食物
- 完成預熱時，蒸爐會發出提示音，請放入食物

### 純蒸







模擬爐火蒸煮，火力精準

適用於肉類、蒸蛋、包點等家常菜

時間	溫度
1分~2小時	35~100 °C

#### 使用方法:

1. 淨水盒加滿水
2. 待機模式時，按 
3. 扭動按鈕選擇時間 
4. 按下按鈕確定時間 
5. 扭動按鈕選擇溫度 
6. 按  開始烹調

### 大火快蒸(自動功能 31)







以大火力於短時間內蒸熟食物，保留食物鮮味

適用於海鮮、蔬菜、急凍食物

時間	溫度
1分~1小時	100 °C

#### 使用方法:

1. 淨水盒加滿水
2. 待機模式時，按 
3. 扭動按鈕選擇自動功能31(大火快蒸) 
4. 按  確定功能
5. 扭動按鈕選擇時間 
6. 按  開始烹調

### 穩火慢燉(自動功能 32)









以溫和火力燉煮食物

適用於燉品、慢煮

時間	溫度
1分~5小時	35~100 °C

#### 使用方法:

1. 淨水盒加滿水
2. 待機模式時，按 
3. 扭動按鈕選擇自動功能32(穩火慢燉) 
4. 按  確定功能
5. 扭動按鈕選擇時間 
6. 按下按鈕確定時間 
7. 扭動按鈕選擇溫度 
8. 按  開始烹調

### 熱風對流烤焗/炸









火力均勻，金黃香脆

爐內背部設有風扇，使熱力均勻散布整個爐腔，烤焗出色澤金黃的食物

適用於烘焗肉類、炸物、烘焙蛋糕、麵包等

時間	溫度
1分~2小時	100~230°C

#### (無預熱)使用方法: (有預熱)使用方法:

1. 待機模式時，按 
  2. 扭動按鈕選擇溫度 
  3. 按下按鈕確定溫度 
  4. 扭動按鈕選擇時間 
  5. 按  開始烹調
1. 待機模式時，按 
  2. 按  選擇預熱
  3. 扭動按鈕選擇預熱後的烹調溫度 
  4. 按下按鈕確定溫度 
  5. 扭動按鈕選擇烹調時間 
  6. 按  開始預熱
  7. 預熱完成後，放入食物，再按  開始烹調

\*您可以在烹調和暫停期間調整烹調時間。扭動按鈕調整時間後，按  確認設定

### 蒸氣烤焗















減油減鹽，外脆內軟

在熱風對流過程中加入蒸氣烹調，為食物提供水分令食物快速烤熟且鎖住內部水分，保留原始鮮味

適用於烤焗蔬菜、麵包蛋糕、肉類

時間	溫度
1分~2小時	100~230°C

#### (無預熱)使用方法: (有預熱)使用方法:

1. 淨水盒加滿水
  2. 待機模式時，按 
  3. 扭動按鈕選擇溫度 
  4. 按下按鈕確定溫度 
  5. 扭動按鈕選擇時間 
  6. 按  開始烹調
1. 淨水盒加滿水
  2. 待機模式時，按 
  3. 按  選擇預熱
  4. 扭動按鈕選擇預熱後的烹調溫度 
  5. 按下按鈕確定溫度 
  6. 扭動按鈕選擇烹調時間 
  7. 按  開始預熱
  8. 預熱完成後，放入食物，再按  開始烹調

\*您可以在烹調和暫停期間調整烹調時間。扭動按鈕調整時間後，按  確認設定

## 預熱

可選擇預熱溫度

100~230 °C

### 使用方法:

1.待機模式時, 按 

2.扭動按鈕選擇溫度 → 

3.按  開始預熱

\*預熱完成后需載選擇所需的蒸/燜模式

### 需預熱食譜 (自動功能 01,06-19,21)

### 使用方法:

1.待機模式時, 按 

2.扭動按鈕選擇所需使用的自動功能(例如:21)

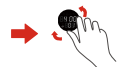

3.按  確定預熱

4.預熱完成後, 放入食物, 再按  開始烹調

\*如功能為蒸煮功能, 水盒請先加滿水

### 無需預熱食譜 (自動功能 02-05,20,22-30)

### 使用方法:

1.待機模式時, 按 

2.扭動按鈕選擇所需使用的自動功能(例如:22)

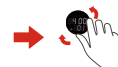

3.按  開始烹調

\*如功能為蒸煮功能, 水盒請先加滿水

## 發酵 (自動功能 33)

穩定發酵溫度, 30-45°C  
溫度選擇

適用於發酵麵糰及乳酪等

時間	溫度
1分~24小時	30~45 °C

### 使用方法:

1.淨水盒加滿水

2.待機模式時, 按 

3.扭動按鈕選擇自動功能33



4.按  確定功能

5.扭動按鈕選擇時間



6.按下按鈕確定時間



7.扭動按鈕選擇溫度



8.按  開始烹調

## 清潔 (自動功能34-37)

### 使用方法:

1.待機模式時, 按 

2.扭動按鈕選擇所需使用的自動功能 (例如:34)

3.按  開始清潔

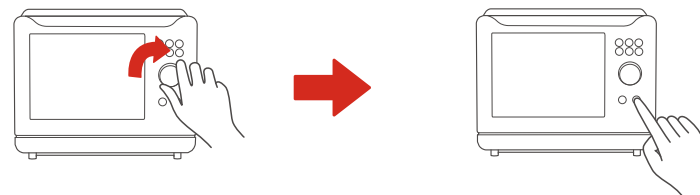

### 餐具消毒 (自動功能 34)

對餐具進高溫殺菌, 此功能適用於各類餐具(耐熱功能高於100°C)的清潔

\*使用餐具清潔功能時, 請務必確認餐具的耐熱溫度高於100°C, 同時確認水盒已加滿水

清潔時間

30分鐘

### 奶瓶消毒 (自動功能 35)

對奶瓶進高溫殺菌

\*使用奶瓶消毒清潔功能時, 請務必確認奶瓶的耐熱溫度高於100°C, 同時確認水盒已加滿水

清潔時間

10分鐘

### 爐腔清潔 (自動功能 36)

用蒸氣及熱力清潔爐腔, 適合烹飪結束後, 選擇此功能進行爐腔清潔, 機器會噴出蒸氣, 軟化污漬, 更容易抹走污漬。

\*使用爐腔清潔功能時, 請確認水盒已加滿水

清潔時間

10分鐘

### 爐腔除味 (自動功能 37)

烹飪結束和進行自動功能36後, 抹淨爐腔, 然後選擇此功能, 利用爐內風扇清除爐腔餘味

清潔時間

5分鐘

# 自動功能表

## 自動功能表指引

螢幕顯示	功能表名稱	火力	時間	放置位置	所需容器
01	清蒸檸檬鱸魚	熱風對流180°C+蒸氣	預熱5分鐘+蒸氣8分20秒	下層	適用碟+蒸盤
02	蒜蓉粉絲蒸蝦	快蒸100°C	約7分30秒	下層	適用碟+蒸盤
03	日式茶碗蒸	純蒸100°C	約24分鐘	下層	茶碗+蒸盤
04	蒸娃娃菜	快蒸100°C	約12分鐘	下層	適用碟+蒸盤
05	牛肉灌湯包	快蒸100°C	約20分鐘	下層	蒸盤
06	戚風蛋糕	熱風對流150°C	約50分鐘	下層	烤盤
07	海鮮披薩	熱風對流220°C	約15分鐘	下層	烤盤
08	香烤雞翼	熱風對流220°C	約25分鐘	下層	烤盤
09	蜜汁燒肋骨	熱風對流220°C+熱風對流180°C	約10分鐘+約15分鐘	下層	烤盤
10	黑椒牛扒	熱風對流230°C	約20分鐘	下層	烤盤
11	迷迭香烤羊架	熱風對流230°C	約40分鐘	下層	烤盤
12	烤秋刀魚	熱風對流220°C	約15分鐘	下層	烤盤
13	炸蝦天婦羅	熱風對流200°C	約18分鐘	下層	烤盤
14	紙杯蛋糕	熱風對流170°C	約23分鐘	下層	烤盤
15	香辣烤魚	熱風對流200°C	約15分鐘	下層	烤盤
16	蔓越莓餅	熱風對流160°C	約16分鐘	下層	烤盤
17	葡撻	熱風對流200°C	約25分鐘	下層	烤盤
18	牛油卷	熱風對流180°C	約12分鐘	下層	烤盤
19	香蔥芝士曲奇	熱風對流180°C	約10分鐘	下層	烤盤
20	香烤紅薯	熱風對流230°C	約50分鐘	下層	烤盤
21	焦糖布丁	熱風對流140°C	約15分鐘	下層	烤盤
22	剝椒魚頭	快蒸100°C	約20分鐘	下層	適用碟+蒸盤
23	玉子豆腐蒸蝦仁	快蒸100°C	約10分鐘	下層	適用碟+蒸盤
24	蒸燒賣	快蒸100°C	約16分鐘	下層	蒸盤
25	蒸急凍食品	快蒸100°C	約15分鐘	下層	蒸盤

26	三文魚蒸飯	純蒸100°C	約8分鐘	下層	適用碟+蒸盤
27	蒸米飯	純蒸100°C	約45分鐘	下層	寬口大碗+蒸盤
28	豉汁蒸排骨	快蒸100°C	約20分鐘	下層	適用碟+蒸盤
29	菠菜紅豆草餅	純蒸100°C	約20分鐘	下層	適用碟+蒸盤
30	燉燕窩	純蒸100°C	約50分鐘	下層	寬口深容器+蒸盤
31	大火快蒸	100°C	約10分鐘	下層	/
32	穩火慢燉	100°C	約50分鐘	下層	/
33	恒溫發酵	35°C	約30分鐘	/	/
34	餐具消毒	/	約30分鐘	/	/
35	奶瓶消毒	/	約10分鐘	/	/
36	爐腔清潔	/	約10分鐘	/	/
37	爐腔除味	/	約5分鐘	/	/

## 爐內燈

在待機或烹調其間可隨意按 ，打開/關閉爐燈，隨時能觀察爐內的食物情況

## 兒童鎖

待機模式時，長按  3秒直至按鈕顯示開啟兒童鎖後將無法使用任何功能



如若取消兒童鎖，請長按  3秒直至  消失

## 待機方法



在待機時(請確保爐內燈已關閉)，按  即可將所有功能顯示燈關閉

任意按下其中功能或打開爐門，即可以取消待機

## 爐溫過高

"F01" 及  出現表示爐腔溫度高於所選擇功能溫度範圍，需待產品冷卻後使用

## 水箱缺水

"FILL" 及  出現表示水箱缺水或未安裝到位，請拉出水盒加水至"MAX"線，再按  繼續烹調。

# 溫馨提示



注意

- 請勿使用粗糙擦洗劑或鋒利的金屬刮刀清潔爐門的玻璃，可能會導致玻璃粉碎
- 請勿將電源線和插頭直接放在外罩上面，以免外罩餘熱損壞電源線
- 爐內處於高溫時，內部水蒸氣膨脹，由於氣壓問題，開門後若立即關門會產生氣鳴聲，屬正常現象，不影響使用。開門後約10秒，爐溫稍微下降，關門即無聲響。

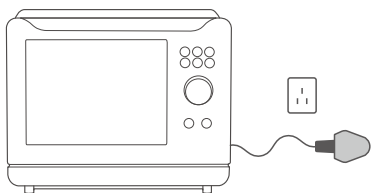

拔掉插頭，待機器  
完全冷卻

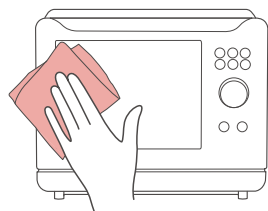

用沾有軟性洗滌劑的布  
塊擦拭產品外殼，再用  
濕布擦淨即可

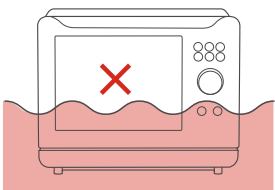

嚴禁將蒸氣焗爐浸  
入水或別的液體中

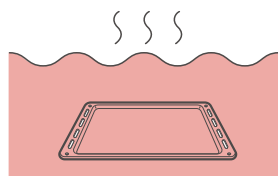

為達到最佳清潔效果，  
建議使用溫水清洗附件

- 烤爐食物時，請鋪上錫紙在烤焗盤上，再放上食物，請勿直接在烤焗盤上沾上酸性物質，如：醋、檸檬、果汁等
- 使用蒸功能後，建議把爐門打開，對排走積水有幫助
- 爐門封條為可拆除式設計，如果水滴或食物殘渣卡在爐門封條，請小心拆除，用扭出水份後的軟布抹拭，抹拭乾淨後，再裝回

# 服務指南

警告

1. 由於蒸氣容易溢出，因此切勿大力刮擦封條
2. 請小心裝拆封條，否則可能泄露蒸氣
3. 使用時，請務必裝回封條

## 故障處理

當發生故障時，若重新通電再啟動後故障仍無法排除，請致電我司客服聯繫專業人員排除故障

## 產品參數

容積	20L	蒸烤功率	1900-2020W
額定電壓/頻率	220-230V~50Hz	外形尺寸（闊x深x高）	410x445x325 mm
熱風對流功率	1300-1380W	爐腔尺寸（闊x深x高）	350x300x200 mm
蒸氣功率	1800-1950W	產品淨重	12.6 kg

1. 產品尺寸順序為闊×深×高，外形深度含手柄、後板拉伸的長度，高度值含爐腳
2. 爐腔尺寸包含拉伸長度，闊深高乘積結果得到爐腔容積。因產品不斷升級，容積參數與標注資料可能存在差異，偏差範圍±12%
3. 由於我們的產品在不斷改進，實物參數可能與標注不同，具體參數請參照實物

產品短片



更多食譜





## Product Introduction

### ! Notes

- If there is any difference between the physical object and the following figure, the physical object shall prevail.
- Please refer to the safety distance marked in the figure to place the product.
- This product is a desktop product, and it is forbidden to be used as a built-in product.

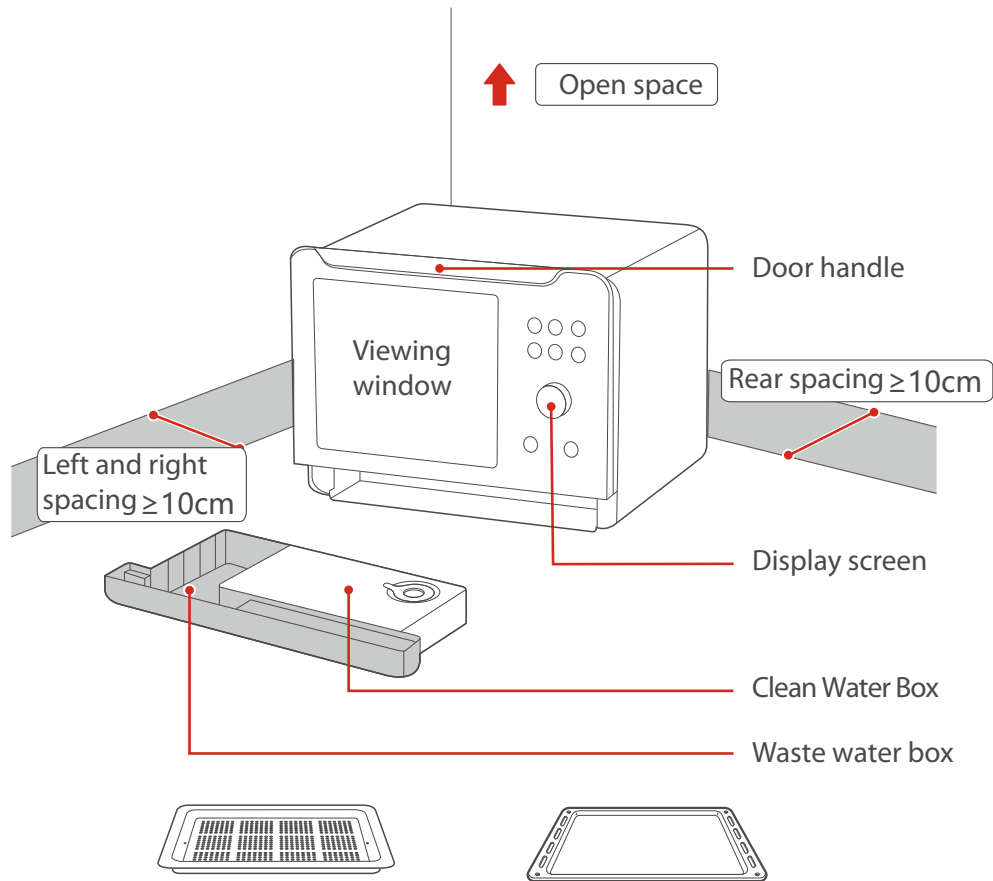

### Steaming tray

(Can only be used in pure steam function)

### Baking tray

(Can be used in convection and combi function.)  
(Please spread tinfoil on the tray when it is used.)

## Initial Use

1. Close the oven door, and do not put anything in the oven.

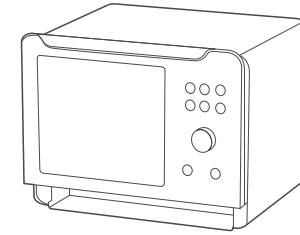

2. Fill up the water box, press the  key and rotate the selector to select 「36 Oven Chamber Cleaning」.

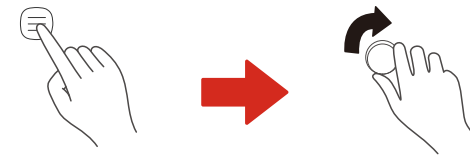

3. Press the  key to start cleaning, which takes about 10 minutes

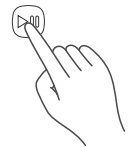

4. When cleaning is completed, the buzzer will sound for one times, and then please open the oven door for cooling.
  - a. Do not touch the oven chamber with your hands immediately after cleaning.
  - b. Please wipe off the accumulated water in the oven chamber with a soft cloth after cooling.
  - c. Do not close the oven door before the chamber is completely cooled down.

## Use of Water Box

### ! Precautions

- When the water box is short of water, the water pump will send out a beep-like prompt to remind the user of water shortage. Please fill the water box with water in time. If the water box is in a water shortage state all the time, the machine will stop working after beeping for 30 seconds, and [beep] will sound every three seconds, and the screen will display [△] and 'FILL' at the same time. Please add water to clean water box until reach "MAX" line, then press [▶] to continue cooking process.

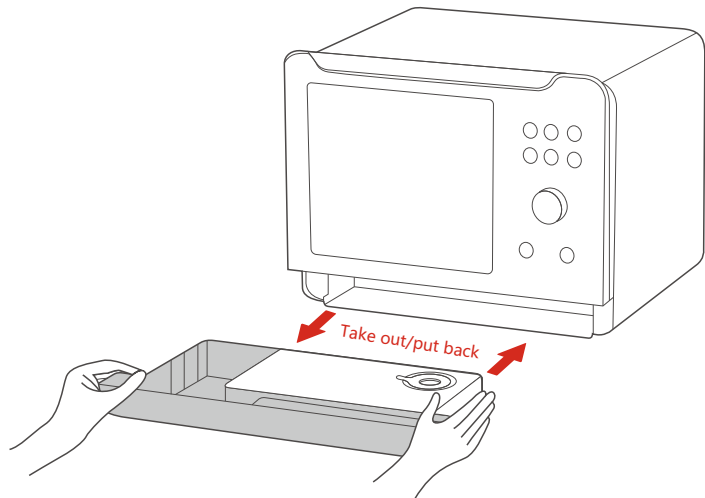

- Add room-temperature boiled water to the water box to avoid scale, so as not to affect the service life of the machine.
- After cooking, the water in the waste water box and clean water box should be drained to avoid breeding bacteria.

### Method of adding water

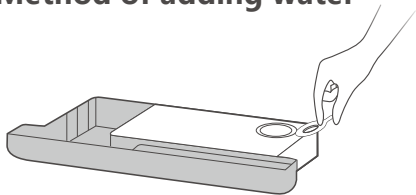

After uncovering the rubber ring, add a proper amount of room temperature boiled water and cover the rubber ring to ensure that it fits well.

### Cleaning method

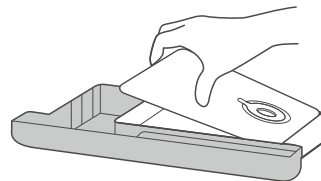

Open the water box cover for cleaning, or pour out the remaining water.

## Control Panel

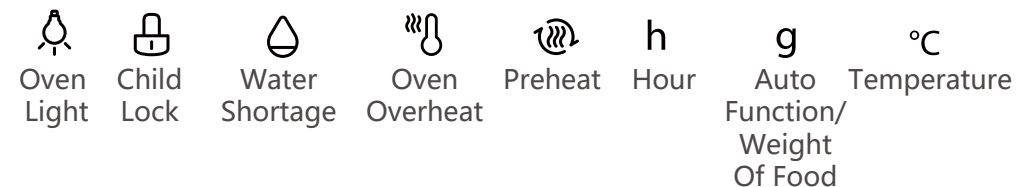
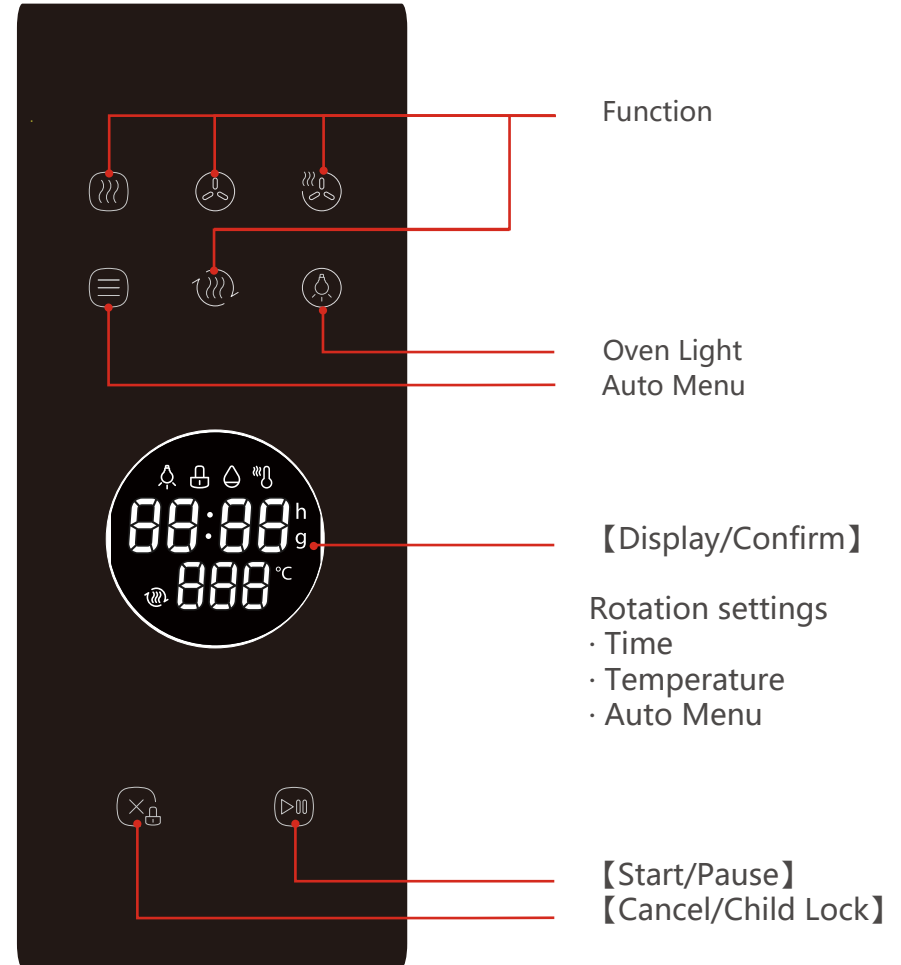

# Operating Process

## ! Notes

- Press the oven lamp  button to turn on/off the oven lamp, so that you can observe the food in the oven chamber at any time.
- Please top up the water box with room-temperature boiled water before using pure steam/ steam baking/ fermenting function.

- When your food is ready, the steam oven will make an audio prompt; please take out your food.
- When preheat is finished, the steam oven will make an audio prompt, please put your food in.

### Steam









Simulated fire cooking, accurate heat power

Suitable for home cooking food such as meat, steamed eggs and buns

Time	Temperature
1 minute to 2 hours	35~100°C

**How to use:**

- 1.Top up the clean water box with room-temperature boiled water
- 2.In standby mode, touch 
- 3.Rotate to select desired time 
- 4.Press  to confirm 
- 5.Rotate to select desired temperature 
- 6.Touch  to start cooking

### Quick Steam

(Auto Menu  31)









Steaming the food in a short time with high heat power to keep the delicious taste of the food

Suitable for home cooking food such as seafood, vegetables and quick-frozen food

Time	Temperature
1 minute to 1 hour	100°C

**How to use:**

- 1.Top up the clean water box with room-temperature boiled water
- 2.In standby mode, touch 
- 3.Rotate to select Auto Menu 31 (fast steaming over high heat power) 
- 4.Touch  to confirm the function 
- 5.Rotate to select desired time 
- 6.Touch  to start cooking

### Slow Stew

(Auto Menu  32)











Simmering food with moderate heat power

Suitable for stews and slowly-cooked food

Time	Temperature
1 minute to 5 hours	35~100°C

**How to use:**

- 1.Top up the clean water box with room-temperature boiled water
- 2.In standby mode, touch 
- 3.Rotate to select Auto Menu 32 (simmering) 
- 4.Touch  to confirm the function 
- 5.Rotate to select desired time 
- 6.Press to confirm 
- 7.Rotate to select desired temperature 
- 8.Touch  to start cooking

### Convection







Evenly distributed heat power, cooking crispy food with golden color

There is a fan at the back of the oven to evenly spread the heat throughout the cavity. Giving your baked food a golden color.





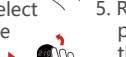

Suitable for baked meat, fried food, baked cake, bread, etc.

Time	Temperature
1 minute to 2 hours	100~230°C

**(Without preheat) How to use:**

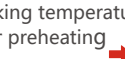
- 1.In standby mode, touch 
- 2.Turn the button to select the temperature 
- 3.Press to confirm 
- 4.Rotate to select desired time 
- 5.Touch  to start cooking

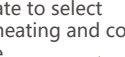
**(With preheat) Usage:**

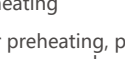
- 1.In standby mode, touch 
- 2.Touch  to select preheat
- 3.Rotate to select the cooking temperature after preheating 
- 4.Press to confirm 
5. Rotate to select preheating and cooking time 
- 6.Touch  to start preheating
- 7.After preheating, put food in the oven and press  to start cooking

\* You can adjust the cooking time during cooking and pause. After turning the button to adjust the time, press  to confirm the setting.

### Combi







Reduced oil and salt, crisp outside and soft inside

Steam is added to cook in the process of hot air convection, which provides water for food to be cooked quickly, locks the internal water and retains the original flavor.



Suitable for baked vegetables, bread, cakes and meat

Time	Temperature
1 minute to 2 hours	100~230°C

**(Without preheat) How to use:**

- 1.Top up the clean water box with room-temperature boiled water
- 2.In standby mode, touch 
- 3.Rotate to select desired temperature 
- 4.Press to confirm 
5. Rotate to select desired time 
- 6.Touch  to start cooking

**(With preheat) Usage:**

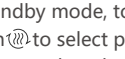
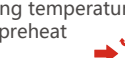
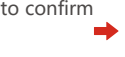
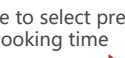
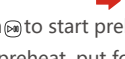
- 1.Top up the clean water box with room-temperature boiled water
- 2.In standby mode, touch 
- 3.Touch  to select preheat
- 4.Rotate to select the cooking temperature after preheat 
- 5.Press to confirm 
- 6.Rotate to select preheat and cooking time 
- 7.Touch  to start preheat
- 8.After preheat, put food in the oven and touch  to start cooking



\* You can adjust the cooking time during cooking and pause. After turning the button to adjust the time, press  to confirm the setting.

## Preheat

Range of preheat temperature

100~230°C

### How to use:



1. In standby mode, touch 
2. Rotate to select desired temperature 
3. Touch  to start preheat

\*Choose steaming/convection again when preheat is finished

### Recipes requiring preheat

(Auto Menu  01,06-19,21)

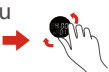
### How to use:



1. In standby mode, touch 
2. Rotate to select desired menu (for example: 21) 
3. Touch  to start preheat
4. After preheat, put food in the oven and touch  to start cooking

\*Please top up the clean water box first if you choose pure steam function

### Recipes requiring no preheat

(Auto Menu  02-05,20,22-30)

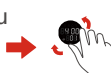
### How to use:

1. In standby mode, touch 
2. Rotate to select desired menu (for example: 22) 
3. Press  to start

\*Please top up the clean water box first if you choose pure steam function







## Fermentation (Auto Menu 33)

Stable fermentation temperature,  
temperature range: 30-45°C  
Suitable for fermented dough,  
yogurt, etc.

Time Temperature



1 minute to 24 hours 30~45°C

### How to use:

1. Top up the clean water box with room-temperature boiled water
2. In standby mode, touch 
3. Rotate to select menu 33 
4. Touch  to confirm the menu
5. Rotate to select desired time 
6. Press to confirm 
7. Rotate to select desired temperature 
8. Touch  to start

## Cleaning (Auto Menu 34-37)

### How to use:

1. In standby mode, touch 
2. Rotate to select desired menu (for example: 34)
3. Touch  to start cleaning

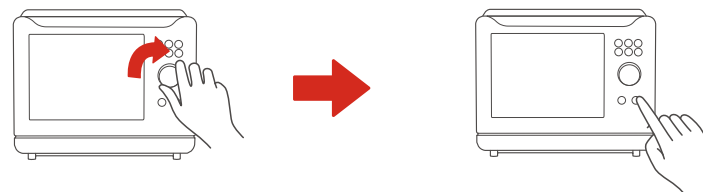

### Tableware disinfection (Auto Menu 34)

This function is suitable for cleaning all kinds of tableware (heat resistance higher than 100°C).

\*When using the tableware cleaning function, please make sure that the heat resistance of tableware is higher than 100°C and that the water box is filled with water.

Cleaning time  
30 minutes

### Milk bottle disinfection (Auto Menu 35)

Use high temperature to sterilize the milk bottle.

\* When using the milk bottle disinfection and cleaning function, please make sure that the heat resistance of the milk bottle is higher than 100°C and that the water box is filled with water.

Cleaning time  
10 minutes

### Cavity cleaning (Auto Menu 36)

Clean the oven cavity with steam and heat, which is suitable for cleaning the oven cavity after cooking. The machine will spray steam to soften the stains, which will make it easier to wipe the stains away

\* When using the oven cavity cleaning function, please confirm that the water box has been filled with water.

Cleaning time  
10 minutes

### Cavity deodorization (Auto Menu 37)

Use it after cooking or after Menu 36. Wipe and clean the cavity first, and then select this function to remove the residual smell from the cavity by the built-in fan.

Cleaning time  
5 minutes

# Auto Menu Setting

Screen display	Menu name	Power	Time	Place to put	Container
01	Steamed Sea Bass with Lime	Convection 180 °C + Full Steam Power	5min Convection Preheat + Steam 8min 20 S	Lower Shelf	Suitable dish + Steaming tray
02	Steamed Garlic Shrimp with Vermicelli Noodles	100 °C Quick Steam	7min 30 S	Lower Shelf	Suitable dish + Steaming tray
03	Japanese Steamed Egg Custard	100 °C Full Steam	24min	Lower Shelf	Tea bowl + Steaming tray
04	Steamed Baby Cabbage	100 °C Quick Steam	12min	Lower Shelf	Suitable dish + Steaming tray
05	Soup Dumplings with Beef	100 °C Quick Steam	20min	Lower Shelf	Steaming tray
06	Chiffon Cake	150 °C Convection	50min	Lower Shelf	Baking tray
07	Seafood Pizza	220 °C Convection	15min	Lower Shelf	Baking tray
08	Roasted Chicken Wings	220 °C Convection	25min	Lower Shelf	Baking tray
09	Honey Glazed Ribs	220 °C Convection + 180 °C Convection	220 °C 10min + 180 °C 15min	Lower Shelf	Baking tray
10	Roasted Steak with Black Pepper	230 °C Convection	20min	Lower Shelf	Baking tray
11	Roasted Lamb Chop with Rosemary	230 °C Convection	40min	Lower Shelf	Baking tray
12	Grilled Saury	220 °C Convection	15min	Lower Shelf	Baking tray
13	Shrimp Tempura	200 °C Convection	18min	Lower Shelf	Baking tray
14	Cupcake	170 °C Convection	23min	Lower Shelf	Baking tray
15	Spicy Grilled Fish	200 °C Convection	15min	Lower Shelf	Baking tray
16	Cranberry Cookies	160 °C Convection	16min	Lower Shelf	Baking tray
17	Portuguese Egg Tarts	200 °C Convection	25min	Lower Shelf	Baking tray
18	Butter Roll	180 °C Convection	12min	Lower Shelf	Baking tray
19	Chives and Cheese Cookies	180 °C Convection	10min	Lower Shelf	Baking tray
20	Roasted Sweet Potato	230 °C Convection	50min	Lower Shelf	Baking tray
21	Caramel Pudding	140 °C Convection	15min	Lower Shelf	Baking tray
22	Steamed Fish Head with Chilli Pepper	100 °C Quick Steam	20min	Lower Shelf	Suitable dish + Steaming tray
23	Steamed Tamago Tofu With Shrimp	100 °C Quick Steam	10min	Lower Shelf	Suitable dish + Steaming tray
24	Steamed Siumai	100 °C Quick Steam	16min	Lower Shelf	Steaming tray
25	Steamed Frozen Food	100 °C Quick Steam	15min	Lower Shelf	Steaming tray

26	Salmon Steamed Rice	100 °C Full Steam	8min	Lower Shelf	Suitable dish + Steaming tray
27	Steamed Rice	100 °C Full Steam	45min	Lower Shelf	Wide-mouth bowl + Steaming tray
28	Steamed Pork Ribs with Black Bean Sauce	100 °C Quick Steam	20min	Lower Shelf	Suitable dish + Steaming tray
29	Sweet Green Rice Ball	100 °C Full Steam	20min	Lower Shelf	Suitable dish + Steaming tray
30	Stewed Bird's Nest	100 °C Full Steam	50min	Lower Shelf	wide-mouth, deep container + Steaming tray
31	Quick Steam	100 °C Steam	10min	Lower Shelf	/
32	Slow Stew	100 °C Steam	50min	Lower Shelf	/
33	Fermentation	35 °C	30min	/	/
34	Tableware Disinfection	/	30min	/	/
35	Milk Bottle Disinfection	/	10min	/	/
36	Cavity Cleaning	/	10min	/	/
37	Cavity Deodorization	/	5min	/	/



## Internal lamp

During standby or cooking, you can touch  to turn on/off the oven lamp, so that you can observe the food in the oven at any time.

## Child lock

In standby mode, press  for 3 seconds until the button is displays



After the child lock is enabled, no function can be used. To cancel the child lock, please press  for 3 seconds until  disappears.

## Operation in standby mode



In standby mode (please make sure that the internal lamp is turned off), press  to turn off all function display lamps.

Press any of the functions or open the oven door to cancel the standby mode.

## Oven overheat

If "F01" and  appears, it indicates that the oven chamber temperature is higher than the functional temperature range, and the product can be used only after it is cooled down.

## Water shortage

If "FILL" and  appears, it indicates that the clean water box is short of water or not installed in place. Please add water to clean water box until reach "MAX" line, then press  to continue cooking process.

# Tips

## ⚠ Precautions

- Do not use coarse scrubbing agent or sharp metal scraper to clean the glass of the oven door, which may cause the glass to shatter.
- Do not put the power cord and plug directly on the outer cover, so as to prevent the residual heat of the outer cover from damaging the power cord.
- When the oven is at high temperature, the internal steam expands. Due to the air pressure, it is normal to hear an air sound if the door is closed immediately after being opened, which does not affect the use. About 10 seconds after opening the door, the oven temperature drops slightly, and there will be no sound during door closing.

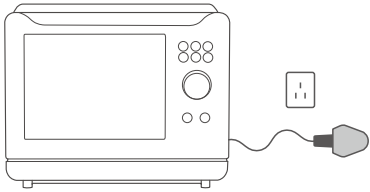

Unplug the machine and wait for the machine to cool down completely.

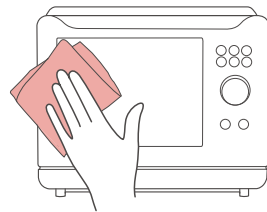

Wipe the product housing with a cloth moistened with soft detergent, and then wipe it with a damp cloth.

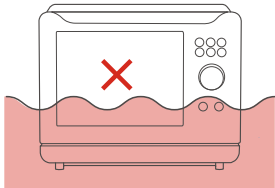

It is strictly forbidden to immerse the steam oven in water or other liquids.

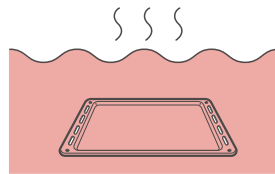

In order to achieve the best cleaning effect, it is recommended to clean accessories with warm water.

- When baking food in the oven, please spread tin foil on the baking tray, and then put the food on it. Please do not directly stain the baking tray with acidic substances, such as vinegar, lemon and juice.
- After using of the steaming function, it is recommended to open the oven door, which is helpful to remove the accumulated water.
- The oven door seal is designed to be removable. If water drops or food residues get stuck in the oven door seal, please remove the seal carefully, wipe it with a soft cloth after wringing out the moisture, wipe it clean, and then put it back.

# Service Guide

## Warning

1. As steam is easy to escape, do not scratch the seal with much effort.
2. Please install/remove the seal carefully; otherwise, steam may leak.
3. Be sure to install the seal before using the oven.

## Troubleshooting

In case of failure, if the failure cannot be cleared after re-energizing and restarting, please call our customer service to contact professionals for eliminating the failure.

## Product Parameters

Volume	20L	Combination	1900-2020W
Rated voltage/ frequency	220-230V~50Hz	Overall dimensions (width x depth x height)	410x445x325 mm
Convection power	1300-1380W	Oven cavity dimensions (width x depth x height)	350x300x200 mm
Steam power	1800-1950W	Net weight of product	12.6 kg

1. The product dimensions are width × depth × height, and the overall depth includes the length of handle and back plate stretching length, and the height value includes oven foot.
2. The dimensions of the oven cavity includes the stretching length, and the cavity volume is obtained by multiplying the width, depth and height. Due to the continuous upgrading of products, there may be differences between volume parameters and labeled data, with a deviation range of ±12%.
3. As our products are constantly improving, the physical parameters may be different from those labeled. Please refer to the physical parameters for specific parameters.

Product videos



More recipes

