

東芝家庭雪櫃

REFRIGERATOR FREEZER

僅供家庭使用

For Home Use Only

GR-RT416WE

GR-RT468WE



- 非常感謝您購買東芝產品。
 - 請閱讀本用戶手冊，並在使用前完全熟悉本產品，以便安全，正確地使用本產品。
 - 請妥善保管本用戶手冊，以備將來參考之用。
-
- Thank you very much for purchasing Toshiba product.
 - Read this Owner's Manual and become completely familiar with the product before use in order to use this product safely and correctly.
 - Keep this Owner's Manual in a handy place for future reference.

目錄

1. 安全警告事項	
1.1 警告	1
1.2 安全警示符號代表意義	4
1.3 用電相關事項	5
1.4 使用時相關事項	6
1.5 放置物品相關事項	7
1.6 能耗警示	8
1.7 廢棄時相關事項	8
2. 如何正確使用雪櫃	
2.1 正確放置雪櫃	9
2.2 調整雪櫃平衡	10
2.3 LED燈更換	11
2.4 啟動	11
2.5 節能提醒	11
3. 雪櫃結構和功能	
3.1 關鍵組件	12
3.2 功能介紹	14
4. 雪櫃的維護及保養	
4.1 整體清潔	17
4.2 玻璃層架清潔	18
4.3 藥妝盒清潔與使用	18
4.4 除霜	19
4.5 停止使用時	19
4.6 製冰盒使用指引	20
5. 常見問題	21
6. 產品廢棄處理	23

CONTENTS

1. Safety warnings	
1.1 Warning	1
1.2 Meanings of safety warning symbols	4
1.3 Electricity related warnings	5
1.4 Warnings for using	6
1.5 Warnings for placement	7
1.6 Warnings for energy	8
1.7 Warnings for disposal	8
2. Proper use of the refrigerator	
2.1 Placement	9
2.2 Leveling feet	10
2.3 Changing the Light	11
2.4 Starting	11
2.5 Energy saving tips	11
3. Structure and functions	
3.1 Key components	12
3.2 Functions	14
4. Maintenance and care of the refrigerator	
4.1 Overall cleaning	17
4.2 Cleaning the glass shelf	18
4.3 Cleaning and use of utility box	18
4.4 Defrosting	19
4.5 Out of operation	19
4.6 Instructions for use ice making box	20
5. Trouble shooting	21
6. Disposal of your appliance	23

1. 安全警告

請在安裝前先閱讀安全注意事項。

為了防止對用戶或他人造成傷害以及財產損失，必須遵循以下使用說明。
由於忽視本使用說明書而導致的不正確操作可能會造成傷害或損壞。

1.1 警告

警告



警告：火災/易燃材料危險

- 警告：火災和爆炸危險電器設備用製冷劑屬於易燃材料，請在安裝和運輸過程中要小心，切勿損壞冷卻管。如果發生氣體洩露，請聯繫經銷商或當地服務代理商，並採取以下預防措施：
 1. 打開窗戶，以確保通風良好。
 2. 周圍嚴禁煙火，請勿使用其他電器設備。
- 本款電器設備指在用於家庭和類似用途，如：商店、辦公室及其他工作環境中的員工廚房區域；酒店、汽車旅館及其他住宅型環境中的農舍及客房；住宿加早餐型環境；餐飲和類似的非零售用途。
- 請監管兒童，以防止他們玩弄電器設備。
- 警告：小心火災和觸電危險。電源線損壞時應及時更換，請聯繫經銷商或當地服務代理商進行更換。
- 清洗電器設備時，或者長時間不使用電器設備時，請從插座上拔下電源插頭。
- 請勿使用延長電線或不接地的（雙插針）變壓器。

1. Safety warnings

READ SAFETY PRECAUTIONS BEFORE INSTALLATION

To prevent injury to the user or other people and property damage, the following instructions must be followed. Incorrect operation due to ignoring of instructions may cause harm or damage.

1.1 Warning

WARNING



Warning : risk of fire / flammable materials

- WARNING: Risk of fire disaster and explosion
The refrigerant of the appliance is flammable, please be care not to damage the cooling pipes during installation and transportation.
If gas leakage happens, please contact the distributor or local service agent, and the following precautions should be always taken:
 1. Open the windows for ensuring good ventilation.
 2. No fire around and please do not use other electric appliance.
- This appliance is intended to be used in household and similar applications such as staff kitchen areas in shops, offices and other working environments; farm houses and by clients in hotels, motels and other residential type environments; bed and breakfast type environments; catering and similar non-retail applications.
- Children should be supervised to ensure that they do not play with the appliance.
- WARNING: Risk of fire disaster and electric shock
The power cord should be replaced when it has been damaged.
Please contact the distributor or local service agent for replacement.
- Please unplug the power plug from socket when clean the appliance or leave the appliance nonuse for a long time.
- Do not use extension cord or ungrounded (two prong) adapters.

-
- 警告：保持電器設備外殼或內置結構中的通風口暢通無阻。
 - 警告：除了製造商推薦的裝置之外，請勿使用機械設備或其他裝置加速解凍過程。
 - 警告：請勿損壞製冷劑迴路。
 - 警告：請勿在電器設備食物儲藏室內使用電器設備，除非這些電器設備屬於製造商推薦的型號。
 - 警告：請按照當地監管法規報廢使用易燃性環戊烷發泡材和制冷劑的雪櫃。
 - 警告：在定位電器設備時，請確保電源線免受夾住或受到損壞。
 - 警告：請勿在電器設備的後面設置多個便攜式插座或便攜式電源。
 - 警告：除了飲用水之外，請勿注入熱水，飲料或其他液體。
 - 危險：小心兒童被夾住的危險。
在扔掉廢舊雪櫃或冰櫃之前：
 - 必須先拆除雪櫃或雪櫃門和門密封件。
 - 先把架子放好，這樣孩子就不會輕易爬進去。
 - 在嘗試安裝附件之前，必須將雪櫃與電源斷開。
 - 雪櫃用製冷劑和環戊烷發泡材料屬於易燃材料。因此，雪櫃在報廢時，應遠離火源，並由具有相應資質的專門回收公司進行回收，而不是通過燃燒加以處理，以防止對環境造成破壞或其他危害。
 - WARNING: Keep ventilation openings, in the appliance enclosure or in the built-in structure, clear of obstruction.
 - WARNING: Do not use mechanical devices or other means to accelerate the defrosting process, other than those recommended by the manufacturer.
 - WARNING: Do not damage the refrigerant circuit.
 - WARNING: Do not use electrical appliances inside the food storage compartments of the appliance, unless they are of the type recommended by the manufacturer.
 - WARNING: Please abandon the refrigerator according to local regulators for its use flammable cyclopentane foaming material and refrigerant.
 - WARNING: When positioning the appliance, ensure the supply cord is not trapped or damaged.
 - WARNING: Do not locate multiple portable socket-outlets or portable power supplies at the rear of the appliance.
 - WARNING: Please fill with potable water only. Please do not fill hot water or liquids other than potable water such as juices.
 - DANGER: Risk of child entrapment. Before you throw away your old refrigerator or freezer:
 - Remove doors and door seals.
 - Leave the shelves in place so that children may not easily climb inside.
 - The refrigerator must be disconnected from the source of electrical supply before attempting the installation of accessory.
 - Refrigerant and cyclopentane foaming material used for the refrigerator are flammable. Therefore, when the refrigerator is scraped, it shall be kept away from any fire source and be recovered by a special recovering company with corresponding qualification other than be disposed by combustion, so as to prevent damage to the environment or any other harm.

-
- 8歲以上的兒童以及身體，感官或精神能力有缺陷，或者缺乏經驗和知識的人士，如果已接受有關安全使用本電器設備的監督或指導，並能了解其中的危險，則可以使用本款電器設備。
兒童不得玩弄本產品。
兒童不得在無人監督的情況下進行清洗和使用維護。
 - 本電器設備不適用於身體，感官或精神能力有缺陷，或者缺乏經驗和知識的人士（其中包括：兒童）使用，除非由負責其安全的人員就本產品的使用對其進行了監督或指導。
 - 請勿在交通運輸工具（如：船舶等）上使用本產品。
 - 如果發生噪聲、異味或冒煙等情況，請立即拔下電源插頭，並與經銷商或當地服務代理商聯繫。
 - 請勿將手放在設備下方或後面，以免受傷。
 - 請將包裝材料及其他部件放在兒童接觸不到的地方，以免造成窒息危險。
 - 為了避免食物受到污染，請遵循以下使用說明：
 - 長時間打開門可能會導致電器設備儲藏室的溫度大幅度升高。
 - 定期清洗可能與食物和易於檢修的排水系統接觸的表面。
 - 如果水箱已有48小時未使用，則必須將水箱清洗乾淨；如果有5天未抽水，則必須沖洗連接到水源的供水系統（注1）。
 - 將生肉和魚存放在雪櫃適當的容器中，以免與其他食物接觸或滴到其他食物上。
 - 二星級☆☆儲藏室適用於儲存預冷凍食品，儲存或製作冰淇淋，以及製作冰塊。

-
- This appliance can be used by children aged from 8 years old or above and persons with reduce physical sensory or mental capabilities or lack of experience and knowledge if they have been given supervision or instruction concerning use of the appliance in a safe way and understand the hazards involved. Children shall not play with the appliance. Cleaning and user maintenance shall not be made by children without supervision.
 - This appliance is not intended for use by persons (including children) with reduced physical, sensory or mental capabilities, or lack of experience and knowledge, unless they have been given supervision or instruction concerning use of the appliance by a person responsible for their safety.
 - Please do not use the appliance on transportation tools (such as ship and so on).
 - If noise, odor and smoking happens, please unplug the power plug immediately, and contact the distributor or local service agent.
 - Please do not put your hands under or behind the appliance to prevent from being hurt.
 - Please leave the packing materials and other parts out of the reach of children to prevent from risk of suffocation.
 - To avoid contamination of food, please respect the following instructions:
 - Opening the door for long periods can cause a significant increase of the temperature in the compartments of the appliance.
 - Clean regularly surfaces that can come in contact with food and accessible drainage systems.
 - Clean water tanks if they have not been used for 48h; flush the water system connected to a water supply if water has not been drawn for 5days. (note 1)
 - Store raw meat and fish in suitable containers in the refrigerator, so that it is not in contact with or drip onto other food.
 - Two-star☆☆ compartments are suitable for storing pre-frozen food, storing or making ice-cream and making ice cubes. (note 2)

- 一星級 (*), 二星級 (**), 和三星級 (***)
儲藏室不適用於冷凍新鮮食品。

- 製冷電器設備如果長期空置，
則應切斷（電源），進行解凍，清洗和風乾，
並打開門，以防止其內部發霉。

- 注1、2和3：請根據您的產品儲藏室型號確認
本產品是否適用。
- 對於獨立式電器設備來說：本款製冷電器設備
並非旨在用作內置式電器設備。

- One -star (*), two-star (**), three-star (***)
compartments are not suitable for the freezing
of fresh food. (note 3)

- If the refrigerating appliance is left empty for
long periods, switch of, defrost, clean, dry, and
leave the door open to prevent mould
developing within the appliance.

- Note 1,2,3: Please confirm whether it is applicable
according to your product compartment type.
- For a freestanding appliance: this refrigerating
appliance is not intended to be used as a built-in
appliance.

1.2 安全警示符號代表意義

該符號表示禁止的事項，
其行為必須禁止。
不遵守指示可能會導致產品損壞
或者危及使用者人身安全。



禁止符號

Prohibition symbol

1.2 Meaning of safety warning symbols

This is a prohibition symbol.
Any incompliance with instructions
marked with this symbol may result in
damage to the product or endanger the
personal safety of the user.

該符號表示必須遵守的事項，
其行為必須嚴格按照要求操作執行。
不遵守指示可能會導致產品損壞
或者危及使用者人身安全。



指令符號

Mandatory action symbol

This is a mandatory action symbol.
It is required to operate in strict
observance of instructions marked with
this symbol, otherwise damage to the
product or personal injury may be
caused.

該符號表示需注意的事項，
其行為需要特別注意。
如果不加以防範，
可能導致輕度或者中度的傷害，
或造成產品損傷。



注意符號

Cautioning symbol

This is a cautioning symbol.
Instructions marked with this symbol
require special caution. Insufficient
caution may result in slight or moderate
injury, or damage to the product.

本說明書包含許多重要的安全信息，
請務必遵守所有的安全信息。

**This manual contains lots of important
safety information which shall be
observed by the users.**

1.3 用電相關事項

- 拔掉雪櫃的電源插頭時切勿拉扯電源線。
一定要緊緊握住插頭，
從插座中直接拔出。

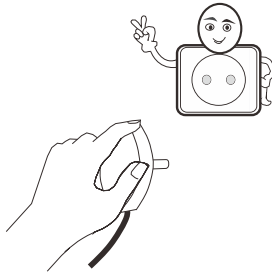

- 為保障安全使用，
任何時候請不要損壞電源線，
當電源線出現破損或插頭出現
磨損時，切勿使用。

- 請勿用濕手觸摸電源插頭，
以免觸電。



- 請使用獨立電源插座，
而且該電源插座不得與其他
電氣設備共用。
電源插頭應與插座牢固接觸，
否則可能會引起火災。

- 請確保電源插座的接地電極配備
可靠的接地線。

- 請具有專業資格的人員幫忙檢查
插座是否配有可靠的接地線。

- 用戶有責任把不接地插座改為
接地插座。

- 請關閉漏氣閥，然後打開門窗，
以防天然氣及其他易燃氣體洩漏。
考慮到火花可能會引起火災，
切勿拔下電冰箱及其他電氣設備的
插頭。



- 請勿在電器設備頂部使用電氣設備，
除非這些電氣設備屬於製造商
推薦的型號。

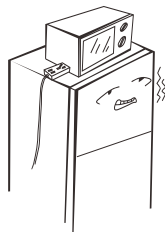

1.3 Electricity related warnings

- Do not pull the power cord when pulling the power plug of the refrigerator.
Please firmly grasp the plug and pull out it from the socket directly.
- To ensure safe use, do not damage the power cord and do not use the power cord when it is damaged or worn.
- Please do not touch the power plug with wet hand to prevent from electric shock.
- Please use a dedicated power socket and the power socket shall not be shared with other electrical appliances. The power plug should be firmly contacted with the socket or else fires might be caused.
- Please ensure that the grounding electrode of the power socket is equipped with a reliable grounding line.
- Please ask for help from persons with professional qualification to examine whether the socket is with reliable grounding line or not.
- It is the users' responsibility to change the ungrounded socket into grounded socket.
- Please turn off the valve of the leaking gas and then open the doors and windows in case of leakage of gas and other flammable gases. Do not unplug the refrigerator and other electrical appliances considering that spark may cause a fire.
- Do not use electrical appliances on the top of the appliance, unless they are of the type recommended by the manufacturer.

1.4 使用時相關事項

- 嚴禁私自拆卸，改造本雪櫃，禁止損壞製冷管路，維修雪櫃必須由專業人員進行。
- 如果電源線損壞，為了避免危險，必須由銷售商或其維護部門相關的專業人員更換。
- 門與門之間以及門與雪櫃箱體之間的間隙很小，注意不要把手伸到這些區域內，以防擠傷手指。開關雪櫃門時，用力不要過大，以免物品掉落。
- 雪櫃開始運行之後，不要用濕手去拿冷凍室內的食品或容器，特別是金屬容器，以免凍傷手。
- 切勿讓任何兒童進入或爬上雪櫃；否則可能會造成兒童窒息或跌傷。
- 請勿將重物或危險物品（如：瓶子，餐具或盛有液體的物品）放置在電器設備的頂部。

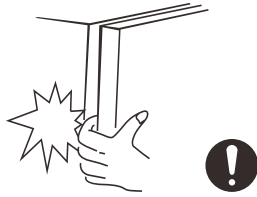
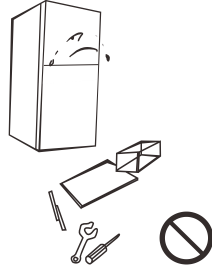

1.4 Warnings for using

- Do not arbitrarily disassemble or reconstruct the refrigerator, or damage the refrigerant circuit; maintenance of the appliance must be conducted by a specialist.
- Damaged power cord must be replaced by the manufacturer, its maintenance department or related professionals in order to avoid danger.
- The gaps between refrigerator doors and between doors and refrigerator body are small, be noted not to put your hand in these areas to prevent from squeezing the finger. Please close it gentle when close the refrigerator door to avoid falling contents.
- Do not pick foods or containers with wet hands in the freezing chamber when the refrigerator is operating, especially metal containers in order to avoid frostbite.
- Do not allow any child to get into or climb the refrigerator; otherwise suffocation or falling injury of the child may be caused.
- Please do not put heavy or dangerous objects on top of the appliance. (bottles, tableware, or something containing liquid)

1.5 放置物品相關事項

- 請不要將易燃，易爆，易揮發和強腐蝕性物品放入電器，以免導致產品損壞或火災等事故。
- 請不要在雪櫃附近放置或使用可燃性物品，以免發生火災。
- 本雪櫃為家用雪櫃，家用雪櫃只適用於儲藏食品；不能用於其他用途，如儲藏血液，藥品和生物製品等。
- 請不要將瓶裝或密閉容器內的所含液體如瓶裝啤酒，飲料等放入冷凍室，以免凍結爆裂導致其他損失。

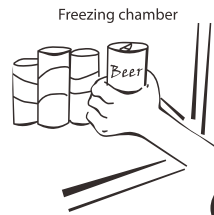

1.5 Warnings for placement

- Do not put flammable, explosive, volatile and highly corrosive items in the refrigerator to prevent damages to appliances or stored articles or fire accidents.
- Do not place flammable items near the refrigerator to avoid fires.
- The refrigerator is intended for household use, such as storage of foods; it shall not be used for other purposes, such as storage of blood, drugs or biological products, etc.
- Do not store beer, beverage or other fluid contained in bottles or enclosed containers in the freezing chamber of the refrigerator; or otherwise the bottles or enclosed containers may crack due to freezing to cause damage to appliances or stored articles.

1.6 能耗警示

- 當食物放置在為製冷電器設備設計的溫度範圍的冷電位端以下較長時間時，製冷設備可能無法持續運行（可能會使冷凍室內的儲藏物解凍或者使冷凍室內的溫度過高）。
- 請勿將起泡性飲料存放在食品冷凍室或冷凍櫃中或低溫冷藏室或冷藏櫃中，也不要飲用太涼飲料。
- 對於任何種類的食品，特別是對於在食品冷凍室或冷凍櫃和冷凍食品儲藏室或儲藏櫃中的商用速凍食品，請勿超過食品製造商推薦的儲存時間。
- 為了防止在製冷電器設備解凍時冷凍食品的溫度過高，應採取一些預防措施，如：將冷凍食品包裝在幾層報紙中。
- 在手動解凍，維護或清洗過程中，冷凍食品的溫度升高可能會縮短冷藏壽命。

1.7 廢棄時相關事項

- 該雪櫃使用的製冷劑和環戊烷發泡材料均為可燃性材料，廢棄雪櫃應與火源隔絕，不能燃燒處理。請交給具有資質的專業回收公司處理。以避免對環境造成危害或引發其它危險。
- 當雪櫃報廢時，請拆下雪櫃門及其密封件。請將架子放在適當的地方，以免任何孩子被卡住。



1.6 Warnings for energy

- Refrigerating appliances might not operate consistently (possibility of defrosting of contents or temperature becoming too warm in the freezing chamber) when sited for an extended period of time below the cold end of the range of temperatures for which the refrigerating appliance is designed.
- Effervescent drinks should not be stored in food freezer compartments or containers or in low-temperature compartments or containers, and that should not be consumed too cold.
- Do not exceed the storage time(s) recommended by the food manufacturers for any kind of food and particularly for commercially quick-frozen food in food-freezer and frozen-food storage compartments or containers.
- To prevent an undue rise in the temperature of the frozen food while defrosting the refrigerating appliance, it should take precautions such as wrapping the frozen food in several layers of newspaper.
- A rise in temperature of the frozen food during manual defrosting, maintenance or cleaning could shorten the storage life.

1.7 Warnings for disposal

- Refrigerant and cyclopentane foaming material used for the refrigerator are flammable. Therefore, when the refrigerator is scrapped, it shall be kept away from any fire source and be recovered by a special recovering company with corresponding qualification other than be disposed by combustion, so as to prevent damage to the environment or any other harm.
- When the refrigerator is scrapped, disassemble the doors, and remove the seal; leave the shelves in a proper place, so as to prevent trapping of any child.

2. 如何正確使用雪櫃

2.1 正確放置雪櫃

- 在初始啟動之前，請先將雪櫃靜置兩個小時，然後再接通電源。
- 在移動雪櫃之前，請將雪櫃內的所有物品取出，用膠帶固定玻璃隔板，蔬菜架、冷凍室抽屜等部件，並轉緊可調節高度架；關上雪櫃門，然後用膠帶密封。在移動過程中，電器設備不得過度倒置或水平放置或受到振動；在移動過程中，傾斜角不得超過45°。

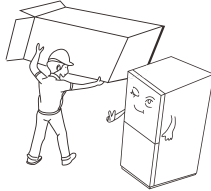
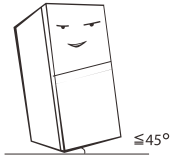

- 使用前，請拆除雪櫃內的所有包裝材料，其中包括：底墊、泡沫墊和膠帶；撕下雪櫃門和箱體上的保護膜。請遠離熱源並避免陽光直射。請勿將本產品放置在潮濕或有水的地方，以防生鏽或降低絕緣效果。

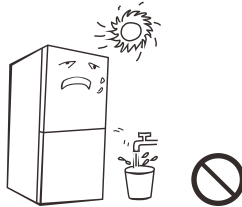

- 不要用水噴淋，沖洗雪櫃，也不要將其放置在潮濕，易濺上水的地方，以免影響雪櫃產品的電氣絕緣性能。

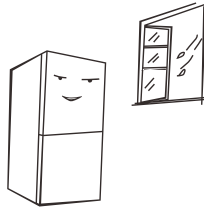

- 將雪櫃放置在室內通風良好的地方，地面平坦、堅固（如有不平穩，可向左或向右旋轉調整腳水平）。

- 雪櫃頂部預留空間大於30cm，兩側及背部與牆雖預留大於10cm的距離，便於雪櫃門的開合及散熱。

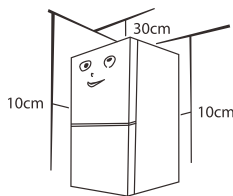

安裝前提示:在嘗試安裝或調試之前，必須保證雪櫃不接通電源。請做好防護，以免造成人身傷亡。



2. Proper use of the refrigerator

2.1 Placement

- Before initial start, keep the refrigerator still for two hour before connecting it to power supply.
- Before the refrigerator is moved, take all objects inside out, fix the glass shelves, freezing chamber drawers and etc. with tape, and tighten the leveling feet; close the doors and seal them with tape. During moving, the appliance shall not be laid upside down or horizontally, or be vibrated; the inclination during movement shall be no more than 45°.
- Before use, remove all packing materials, including bottom cushions, foam pads and tapes inside of the refrigerator; tear of the protective film on the doors and the refrigerator body. Keep away from heat and avoid direct sunlight. Do not place the appliances in moist or watery places to prevent rust or reduction of insulating effect.
- Do not spray of liquid and etc. or wash the refrigerator; do not put the refrigerator in moist places easy to be splashed with water so as not to affect the electrical insulation properties of the refrigerator.
- The refrigerator should placed in a well-ventilated indoor place; the ground shall be fat, and sturdy (rotate left or right to adjust the leveling feet for leveling if unstable).
- The top space of the refrigerator shall be greater than 30cm, and the refrigerator should be placed against a wall with a free distance more than 10cm to facilitate heat dissipation.

Precautions before installation: Before installation or adjusting of accessories, it shall be ensured that the refrigerator is disconnected from power.

2.2 調整雪櫃平衡

調節步驟:

- 底腳順時針旋轉升高雪櫃。
- 底腳逆時針旋轉降低雪櫃。
- 根據上述步驟，
將雪櫃兩底腳調節至水平高度即可。

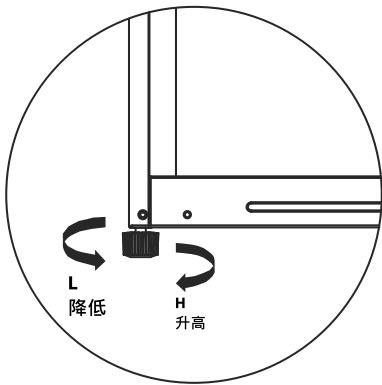

2.2 Leveling feet

Adjusting procedures:

- Turn the feet clockwise to raise the refrigerator;
- Turn the feet counterclockwise to lower the refrigerator;
- Adjust the right and left feet based on the procedures above to a horizontal level.

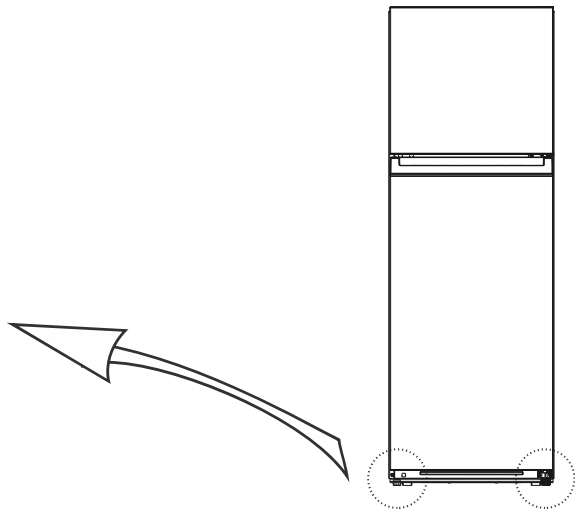

(以上圖片僅供參考，實際配置以購買實物或銷售商聲明為準)

(The picture above is only for reference. The actual configuration will depend on the physical product or statement by the distributor)

2.3 LED燈更換

LED指示燈的任何更換或維護均應由製造商及其服務代理商或符合資格的人員負責進行。

2.4 啟動

- 雪櫃首次啟動請靜置兩小時後再插上電源。
- 在裝入新鮮或冷凍食品前，先讓雪櫃運行2~3小時；夏季環境溫度較高，應先讓雪櫃充分運行4小時以上。
- 為保障開門順暢及抽屜等取出方便，請留出足夠的空間或以銷售商聲明為準。

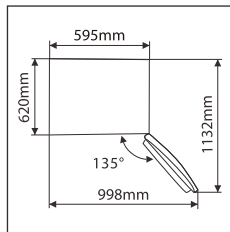
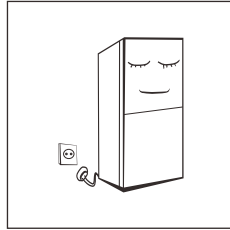

2.5 節能提醒

- 應將電器設備設置在室內最涼爽的地方，遠離加熱器或加熱管，並避免陽光直射。
- 在將熱食放入電器設備之前，請將其冷卻至室溫。設備過載會迫使壓縮機運行更長的時間。
- 冷凍太慢的食物可能會變質或變壞。
- 確保正確包裝食物，並將容器擦乾，然後再將其放入電器設備中。這樣可以減少電器設備內部的積霜。
- 電器設備儲物箱不應襯有鋁箔、蠟紙或紙巾。內襯會幹擾冷空氣循環，從而降低電器設備的效率。整理好食物並貼上標籤，以減少開門次數並擴大搜索範圍。一次取出盡多樣物品，開盡快關閉雪櫃門。

2.3 Changing the Light

Any replacement or maintenance of the LED lamps is intended to be made by the manufacture, its service agent or similar qualified person.

2.4 Starting

- Before initial start, keep the refrigerator still for two hours before connecting it to power supply.
- Before putting any fresh or frozen foods, the refrigerator shall have run for 2-3 hours, or for above 4 hours in summer when the ambient temperature is high.
- Spare enough space for convenient opening of the doors and drawers or spare statement by the distributor.

2.5 Energy saving tips

- The appliance should be located in the coolest area of the room, away from heat producing appliances or heating ducts, and out of the direct sunlight.
- Let hot foods cool to room temperature before placing in the appliance. Overloading the appliance forces the compressor to run longer.
- Foods that freeze too slowly may lose quality, or spoil.
- Be sure to wrap foods properly, and wipe containers dry before placing them in the appliance. This cuts down on frost build-up inside the appliance.
- Appliance storage bin should not be lined with aluminum foil, wax paper, or paper toweling. Liners interfere with cold air circulation, making the appliance less efficient. Organize and label food to reduce door openings and extended searches. Remove as many items as needed at one time, and close the door as soon as possible.

3. 如何正確使用雪櫃

3. Structure and functions

3.1 關鍵組件

3.1 Key components

GR-RT416WE

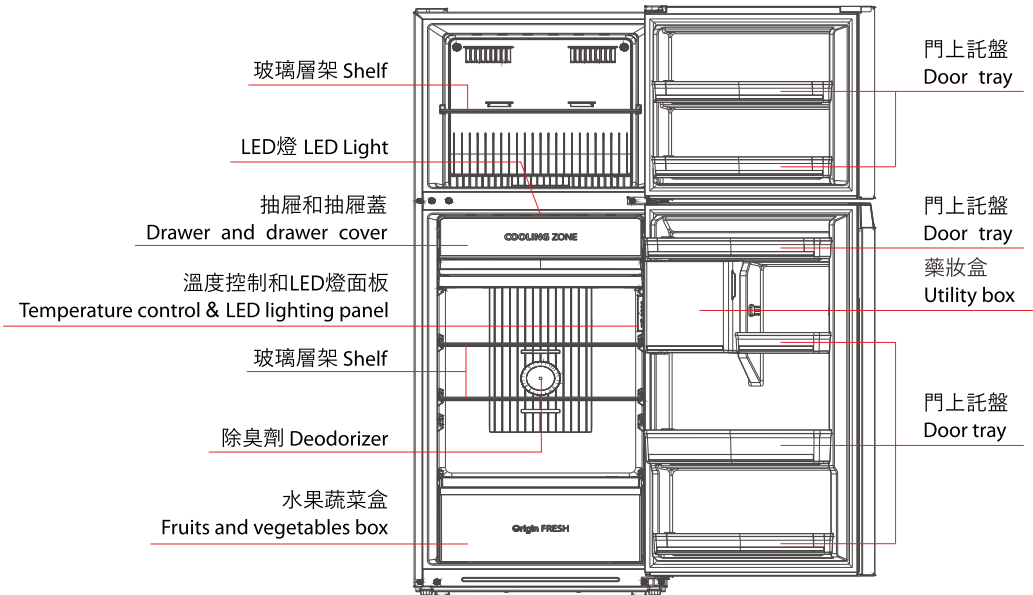

GR-RT468WE

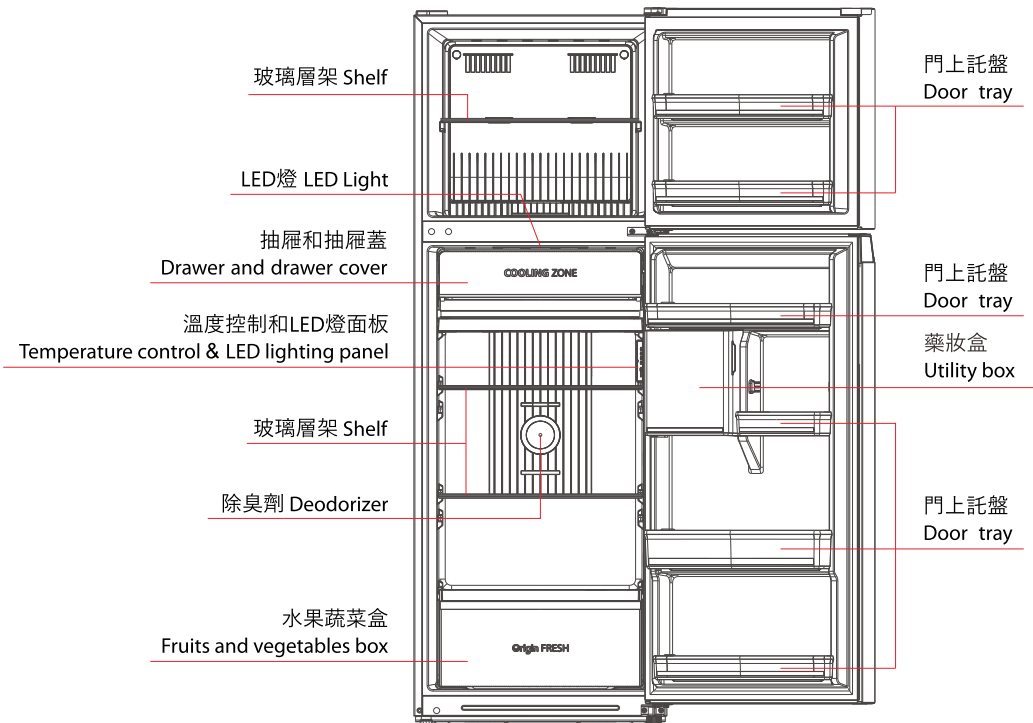

(以上圖片僅供參考, 實際配置以購買實物或銷售商聲明為準)

(The picture above is only for reference. The actual configuration will depend on the physical product or statement by the distributor)

冷藏室

- 冷藏室適宜存放各種水果、蔬菜、飲料等短期內食用的食品。
- 烹調類食品冷卻至室溫後放入冷藏室冷藏。
- 食品在放入本電器產品之前最好將其密封起來。
- 玻璃擱架可以上下活動調整位置來達到合理的儲存空間，方便使用。

冷凍室

- 冷凍室低溫可以長時間保持食品新鮮狀態。主要用來儲存冷凍食品及製作冰塊。
- 冷凍室適宜存放肉類、魚蝦等短期不食用的食品。
- 大塊的肉類盡量分割成小塊再放入，便於取用。
- 請注意在產品有效保質期內食用。

Refrigerating chamber

- The Refrigerating chamber is suitable for storage of a variety of fruits, vegetables, beverages and other food consumed in the short term.
- Cooking foods shall not be put in the refrigerating chamber until cooled to room temperature.
- Foods are recommended to be sealed up before putting into the refrigerator.
- The glass shelf can be adjusted up or down for a reasonable amount of storage space and easy use.

Freezing chamber

- The freezing chamber may keep food fresh for a long time and it is mainly used to store frozen foods and making ice.
- The freezing chamber is suitable for storage of meat, fish, rice balls and other foods not to be consumed in short term.
- Chunks of meat are recommended to be divided into small pieces for easy access.
- Please be noted food shall be consumed within the shelf time.

3.2 功能介紹

3.2 Functions

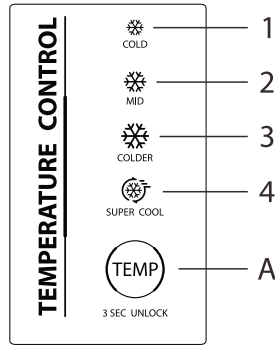

(以上圖片僅供參考, 實際配置以購買實物或銷售商聲明為準)

(The picture above is only for reference. The actual configuration will depend on the physical product or statement by the distributor)

1) 操作按鈕

A: 冷藏室溫度設置按鈕

1) Operation button

A: Temperature setting button of refrigerator compartment

2) 控制面板

1: 設置 1 (弱)

2: 設置 2 (中)

3: 設置 3 (強)

4: 設置 4 (急冷)

2) Control panel

1: setting 1 (COLD)

2: setting 2 (MID)

3: setting 3 (COLDER)

4: setting 4 (SUPER COOL)

3) 顯示器

當雪櫃第一次通電時, 顯示器上的所有按鍵將全部點亮3秒鐘, 然後雪櫃將根據設置3投入運行。

如果發生故障, 相應的LED指示燈就會閃爍。

3) Display

When electrify the refrigerator for first time, all keys on the displaylight up fully for 3 seconds, and then the refrigerator runs accordingto setting 3.

In case of a failure, the corresponding LED blinks.

控制面板 Control Panel	故障描述 Fault Description
指示燈設置1和設置2 Indicator setting 1 and setting 2	冷藏室溫傳感器故障 Temperature sensor of refrigerating chamber failure
指示燈設置1和設置3 Indicator setting 1 and setting 3	冷凍室溫傳感器故障 Defrost sensor of Freezer chamver failure
指示燈設置1和設置4 Indicator setting 1 and setting 4	環境溫傳感器故障 Ambient temperature sensor failure

4) 溫度設置

當每按一次溫度設置按鈕A時，溫度設置就會更改一次。在溫度設置完成之後，冰箱將在15秒後根據設置投入運行。

移行定律是：

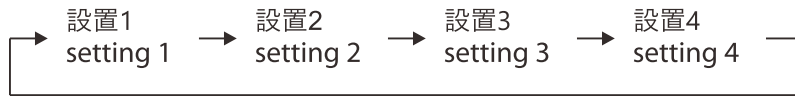

5) 施錠/開錠

當溫度控制面板處於鎖定狀態時，需要長按溫度設置按鈕3秒鐘，才能使面板解鎖。當面板被解鎖時，所有的LED指示燈將閃爍2秒鐘。當溫度控制面板處於解鎖狀態時，如果在15秒鐘內未對控制面板進行任何操作，則控制面板將自動進入鎖定狀態。

6) 阻尼器調節滑塊

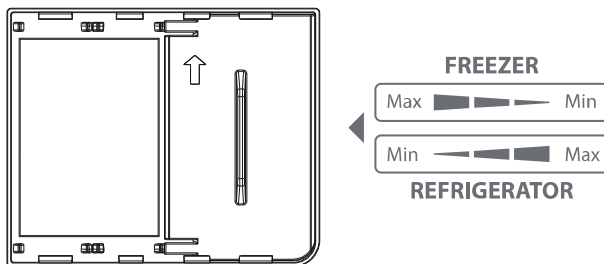

阻尼器調節滑塊應設置在抽屜背面風管的左側。阻尼器調節滑塊的初始位置應位於右側邊緣。如果向左移動阻尼器調節滑塊，則冷凍室中的溫度可能會升高，因此通常建議保持原樣。在環境溫度較低的情況下，當冷凍室溫度升高時，無法檢測到冷凍室的溫度變化。調節阻尼器調節滑塊可以解決這個問題。

4) Temperature setting

Each time the temperature setting button A is pressed once, the temperature setting changes one time. After the temperature setting has been completed, the refrigerator will run according to the set after 15s.

The shift regulation is:

5) Lock/Unlock

When the temperature control panel is in lock state, it needs to long press temperature setting button for 3 seconds for unlocking the panel, all LEDs will blink for 2 seconds when panel is unlocked. When the temperature control panel is in unlock state, if there is no operation on control panel within 15 seconds, it will enter into lock state automatically.

6) Damper adjusting slider

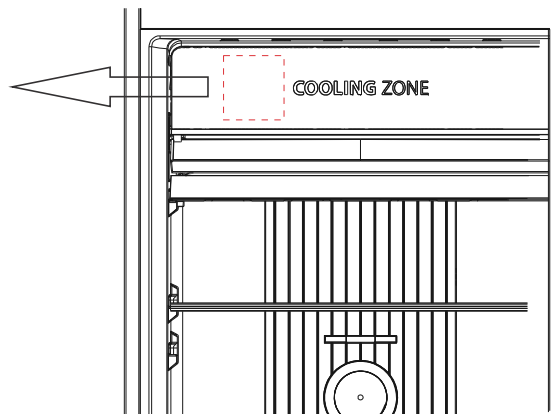

The damper adjustment slider is located on the left side of the duct at the back of the drawer. The initial position of the damper adjustment slider is positioned at the right edge. If you move to the left, there is a possibility that the temperature in the refrigeration chamber will increase, so it is usually recommended to keep it as is. The ambient temperature is low, the temperature of the freezing chamber is not detected, when the temperature of the freezing chamber rises, adjusting the damper adjustment the damper adjustment slider may resolve the issue.

7) 中間風管屬於雪櫃的功能部件，
不建議用戶拆卸該風管。
如果您想拆卸，這將會影響雪櫃的正常
使用。如果需要拆卸，請聯繫經銷商或
當地服務代理商。

7) The middle air duct is a functional part of the refrigerator. It is not supported by the user to disassemble it, if you disassemble it will affect the normal use of the refrigerator. If you need to disassemble it, please contact the distributor or local service agent.

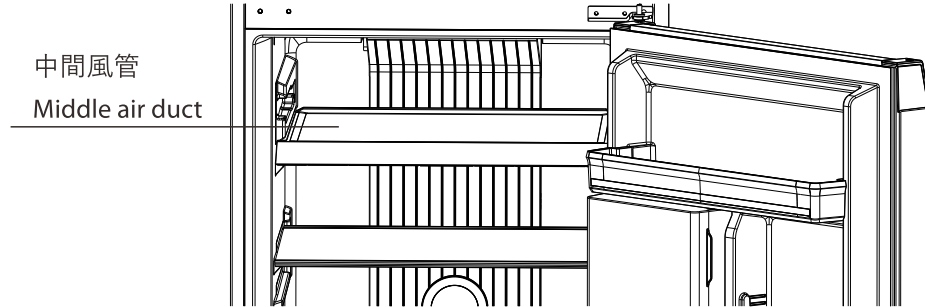

4. 雪櫃的維護及保養

4.1 整體清潔

- 定期檢查門封條，確保清潔沒有雜物。用蘸有肥皂水或稀釋後的清潔劑的軟布清潔門封條。
- 雪櫃內部應經常清潔以免產生異味。
- 清潔雪櫃內部前請先關掉電源，取出所有食物，飲料，層架，抽屜等。
- 清潔雪櫃內膽請使用軟布或者海綿，可以用兩湯匙小蘇打和一公升溫水溶液先清潔一遍，再用清水清洗並擦拭乾淨，清潔完畢後打開門體自然乾燥後再接通電源。
- 對於雪櫃內不易清潔區域（如窄小的夾層，縫隙或拐角），建議用軟布，軟毛刷等和一些必要的輔助工具（如細棍等）進行定期清潔，確保無污染物或細菌聚集。
- 不要使用肥皂，清潔劑，噴霧清潔劑等清潔內膽，因為這些可能會產生異味或污染食物。用沾有肥皂水或稀釋後的清潔劑的軟布清洗瓶框，擱架和抽屜等，然後用軟布擦乾或自然晾乾。用沾有肥皂水，清潔劑等的軟布擦拭雪櫃外表面，然後用軟布擦乾。
- 清潔時請勿使用硬質毛刷、鋼絲球、鋼絲刷、研磨劑（如牙膏），有機溶劑（如酒精、丙酮、香蕉水等），開水、酸鹼性物品，有可能會損傷冰箱表面及內膽。沸水和苯等有機溶劑可能會使塑料部件變形或損壞。
- 清潔時不要用水或其他液體直接衝洗，以免浸泡後造成短路或影響電氣絕緣性能。



 雪櫃進行除霜和清潔時，請先拔下電源插頭。

4. Maintenance and care of the appliance

4.1 Overall cleaning

- Check the door seals regularly to make sure there are no debris. Clean the door seals with a soft cloth dampened with soapy water or diluted detergent.
- The interior of the refrigerator should be cleaned regularly to avoid odor.
- Please turn off the power before cleaning interior, remove all foods, drinks, shelves, drawers, etc.
- Use a soft cloth or sponge to clean the inside of the refrigerator, with two tablespoons of baking soda and a liter of warm water. Then rinse with water and wipe clean. After cleaning, open the door and let it dry naturally before turning on the power.
- For areas that are difficult to clean in the refrigerator (such as narrow sandwiches area, gaps or corners), it is recommended to wipe them regularly with a soft rag, soft brush, etc. and when necessary, combined with some auxiliary tools (such as thin sticks) to ensure no contaminants or bacterials accumulation in these areas.
- Do not use soap, detergent, scrub powder, spray cleaner, etc., as these may cause odors in the interior of the refrigerator or contaminated food. Clean the door tray, shelves and drawers with a soft cloth dampened with soapy water or diluted detergent. Dry with a soft cloth or dry naturally.
- Do not use hard brushes, wire wool, wire brushes, abrasives (such as toothpastes), organic solvents (such as alcohol, acetone, banana oil, etc.), boiling water, acid or alkaline items, which may damage the fridge surface and interior. Boiling water and organic solvents such as benzene may deform or damage plastic parts.
- Do not rinse directly with water or other liquids during cleaning to avoid short circuits or affect electrical insulation after immersion.



 Please unplug the refrigerator for defrost and cleaning.

4.2 玻璃層架清潔

- 稍微向上抬起玻璃擱架後部並向外拉出。
- 完全打開門體，以確保玻璃擱架不會撞到門體。
- 取出玻璃擱架，根據需要進行清潔。
- 按取出逆方向安裝玻璃層架即可。



4.3 藥妝盒清潔與使用

- 取出藥妝盒上方的門托盤。
- 向上抬起藥妝盒並向外取出。
- 將藥妝盒取出，進行清潔。
- 按取出逆方向安裝藥妝盒即可，注意藥妝盒不允許換到另一側安裝使用。
- 打開雪櫃門後，一手扶住雪櫃，另一隻手輕拉旋轉藥妝盒蓋上的把手即可打開藥妝盒蓋；
- 藥妝盒使用完後需關好旋轉盒蓋才可以關上雪櫃門。

4.2 Cleaning the glass shelf

- Lift up the rear of the glass shelf slightly and pull it out.
- Fully open the door and take it out so that the inside of the door and the shelf do not bump.
- Take out the glass shelf and clean it as needed.
- Install the glass shelf in the reverse method of the removal.

4.3 Cleaning and use of utility box

- Take out the door tray in the upward side of the utility box.
- Lift the utility box and take out outward.
- Take out the utility box, and clean it as required.
- Install is the reverse operation.
- Utility box cannot install on the right side area.
- After opening the refrigerator compartment door, hold the refrigerator compartment door with one hand, and gently pull the handle on the lid of the revolving utility box with the other hand to open the lid of the utility box.
- After using the utility box, you need to close the rotating lid before closing the refrigerator compartment door.

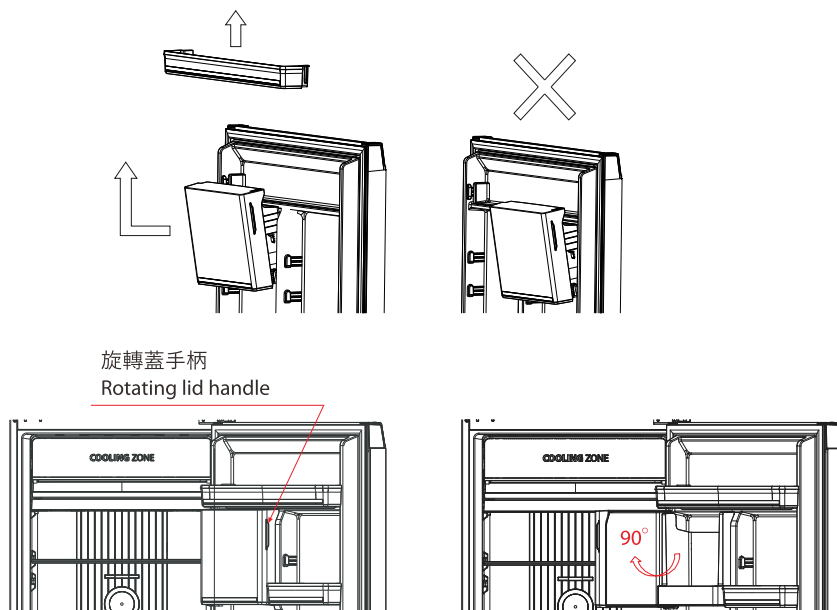

4.4 除霜

- 此雪櫃為風冷原理電器，有自動除霜功能，由於季節或溫度變化，電器內部會有結霜現象，可通過斷電或乾淨毛巾拭擦方式進行手動除霜。

4.5 停止使用時

- 停電時：停電時即使在夏季，食品仍然可以保存幾個小時；期間應盡量減少開門次數，不宜再放入新鮮食品。
- 長時間不使用時：應拔下電源，再對電器進行清潔，並保持雪櫃門敞開，以防止其產生不良氣味。



一旦啟動，設備應連續運行。
一般來說，設備的操作不應中斷；
否則可能會損害使用壽命。

4.4 Defrosting

- The refrigerator is made based on the indirect cooling system and thus has automatic defrosting function. Frost formed due to change of season or temperature may also be manually removed by disconnection of the appliance from power supply or by wiping with a dry towel.

4.5 Out of operation

- Power failure: In case of power failure, even if it is in summer, foods inside the appliance can be kept for several hours; during the power failure, the times of door opening shall be reduced, and no more fresh food shall be put into the appliance.
- Long-time nonuse: The appliance shall be unplugged and then cleaned; then the door are left open to prevent odor.



The appliance shall run continuously once it is started.
Generally, the operation of the appliance shall not be interrupted; otherwise the service life may be impaired.

4.6 製冰盒使用指引

- 製冰盒在使用之前應清洗乾淨。
- 加入適量的水至冰盒的水位線處，然後將製冰盒放置於製冰區域。
- 製冰完成後，按下製冰盒上的按鍵使冰格扭轉，冰塊落入儲冰盒中。
- 向上取出製冰機後即可取儲冰盒中的冰塊。

- ① 加入適量的水
Add an appropriate amount of water

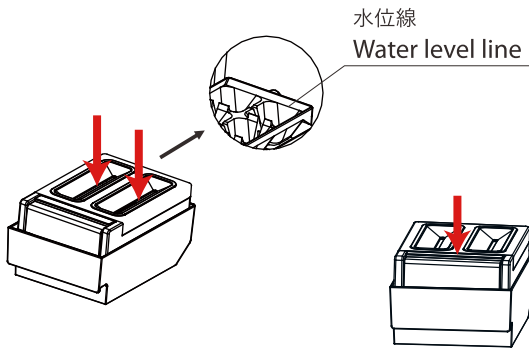

- ② 製冰完成後按下按鍵
Press the button after the ice making is finished

警告

- 請不要加入過量的水溢過水位線和直接將水放到儲冰區域製冰。
- 請不要注入熱水、飲料等飲用水以外的液體。
- 長時間不使用的情况下，應廢棄製冰格中的冰。

4.6 Instructions for use ice making box

- The ice making box should be cleaned before use.
- Add an appropriate amount of water to the water level line on the ice tray, and then place the ice making box in the ice making area.
- After ice making, press the button on the ice making box to twist the ice tray and the ice cubes fall into the ice storage box.
- Take out the ice cubes from the ice storage box after taking out the ice maker upward.

- ③ 向上取出製冰機後即可取冰
Take out the ice after take out the ice maker upward

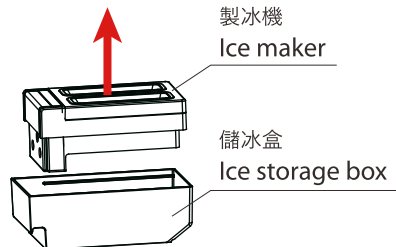

Warning

- Please do not add excess water to overflow the water level line and do not directly put the water into the ice storage box to make ice.
- Please fill with potable water only. Please do not fill hot water or liquids other than potable water such as juices.
- If not used for a long time, the ice cubes in the ice storage box, ice maker, ice cube tray should be discarded.

5. 常見問題

- 對以下一些簡單的問題，您可以嘗試自己動手解決。若沒有改善，請致電售後服務部門。

5. Trouble shooting

- Please try to solve the following simple problems by yourself. If problem cannot be solved, please contact the service department.

故障現象 Occurrence	可能的原因／檢查項目 Possible cause / inspection items
雪櫃無運轉 Operation failure	電源是否接通 插頭是否插牢 電壓是否過低是否停電或者部分電路跳電 Check whether the appliance is connected to power or whether the plug is in well contact. Check whether the voltage is too low. Check whether there is a power failure or partial circuits have tripped.
雪櫃有異味 Odor	有氣味的食品應該嚴密包住 檢查是否有食品腐爛 雪櫃內部需要清潔 Odorous foods shall be tightly wrapped. Check whether there is any rotten food. Clean the inside of the refrigerator.
壓縮機長時間運轉 Long-time operation of the compressor	夏季環境溫度高，雪櫃運轉時間長屬於正常現象 一次性放入食品不宜過多 食品冷卻後再放入雪櫃 開啟雪櫃門次數過於頻繁 Long operation of the refrigerator is normal in summer when the ambient temperature is high. It is not suggestible having too much food in the appliance at the same time. Food shall get cool before being put into the appliance. The doors are opened too frequently.
雪櫃燈不亮 Lighting failure	雪櫃是否通電，照明燈是否損壞照明燈由專業人員更換 Check whether the refrigerator is connected to power supply and whether the illumination light is damaged. Have the light replaced by a specialist.
雪櫃門關不上 Closing door failure	食物包裝卡住門使門無法關上 放入的食品太多雪櫃歪斜 The doors is stuck by food packages. Too much food is placed the refrigerator is tilted.
噪聲大 Loud noise	地面是否平坦，雪櫃放置是否平穩 雪櫃附件是否放在正常位置 Check whether the floor is level and whether the refrigerator is placed on stable ground. Check whether accessories are placed at proper locations.
門封有縫隙 Door is not properly sealed	清除門封上異物，加熱門封使其冷卻後復原（用電吹風或用熱毛巾） Remove foreign matters on the door seal, Heat the door seals and then cool it for restoration. (or blow it with an electrical drier or use a hot towel for heating)
接水盤溢水 Overflowing water from pan	箱內食品存放過多或水分過大，導致化霜水量大 門未關到位等原因導致空氣進入結霜，除霜產生的水增加 There is too much food in the freezing chamber or food stored contains too much water, resulting in heavy defrosting. The doors are not closed properly, resulting in frosting due to entry of air and increased water due to defrosting.

<p>雪櫃外殼發熱 Hot cabinet</p>	<p>內置冷凝器在內部通過外殼散熱，屬於正常現象 環境溫度過高，存放食品過多或壓縮機停機時間段等都或導致外殼發熱注意通風散熱 Heat dissipation of the built-in condenser via the cabinet, which is normal. When cabinet becomes too hot due to high ambient temperature, or storage of too much food, compressor shutdown. Ensure ventilation to facilitate heat dissipation.</p>
<p>外表凝露 Surface condensation</p>	<p>環境濕度過高時，箱體外表和門縫表面會有凝露現象屬於正常現象，用乾淨毛巾拭擦即可 Condensation on the exterior surface and door seals of the refrigerator is normal, when the ambient humidity is too high. Wipe the condensate with a clean towel.</p>
<p>雪櫃有異音 Abnormal noise</p>	<p>嗡嗡聲：壓縮機工作時會產生嗡嗡聲，啟動或停機時聲音較大，屬於正常現象 吱吱聲：電器內部製冷劑流動時會產生吱吱聲，屬於正常現象 Buzz: The compressor may produce buzzes during operation, and the buzzes are loud particularly upon start or stop, which is normal. Creak: Refrigerant flowing inside of the appliance may produce creak, which is normal.</p>

6. 產品廢棄處理

正確處理該產品：

這種標誌表示在整個歐盟中，這種產品不宜與其他家庭垃圾一起處理。為避免因為不受控制的垃圾處理而對環境或人身健康造成潛在傷害，回收垃圾以促進材料資料的可持續重複利用。

要想回收用過的設備，請使用回收或收集系統或聯繫產品零售商。他們可以確保該產品回收環保安全。



6. Disposal of your appliance

Correct Disposal of this product:

This marking indicates that this product should not be disposed with other household wastes throughout the EU.

To prevent possible harm to the environment or human health from uncontrolled waste disposal, recycle it responsibly to promote the sustainable reuse of material resources.

To return your used device, please use the return and collection system or contact the retailer where the product was purchased. They can take this product for environmental safe recycling.

氣候類型

本款電器設備設計用於在由銘牌上標明其類別指定的環境溫度下投入運行。

AMBIENT TEMPERATURE

This appliance is designed to operate in ambient temperature specified by its category marked on the rating plate.

氣候類型 Climate category	環境溫度(從---至---) Ambient temperature (from...to...)
SN	+10°C ~ +32°C
N	+16°C ~ +32°C
ST	+16°C ~ +38°C
T	+16°C ~ +43°C

