

MICROWAVE OVEN INSTRUCTION MANUAL ML-EC42S(BS)



TOSHIBA

CONTENTS

PRODUCT SAFETY

IMPORTANT SAFETY INSTRUCTIONS	EN-3
-------------------------------------	------

PRODUCT INTRODUCTION

PRECAUTIONS MICROWAVE ENERGY	EN-7
GROUNDING INSTRUCTIONS	EN-8
MATERIALS YOU CAN USE IN MICROWAVE OVEN	EN-10
MATERIALS CAN NOT BE USED IN MICROWAVE OVEN	EN-11

INSTRUCTION FOR USE

SETTING UP YOUR OVEN	EN-12
OPERATION INSTRUCTIONS	EN-15

MAINTENANCE

TROUBLE SHOOTING	EN-26
------------------------	-------

 <p>NOTE</p>	<p>BEFORE OPERATING THIS PRODUCT, READ, UNDERSTAND, AND FOLLOW THESE INSTRUCTIONS. BE SURE TO SAVE THIS BOOKLIST FOR FUTURE REFERENCE</p>
--	---

IMPORTANT SAFETY INSTRUCTIONS



SAFETY WARNING

WARNING

To reduce the risk of fire, electric shock, injury to persons or exposure to excessive microwave oven energy when using your appliance, follow basic precautions, including the following:

- Read and follow the specific: "**PRECAUTIONS TO AVOID POSSIBLE EXPOSURE TO EXCESSIVE MICROWAVE ENERGY**".
- This appliance is not intended for use by persons (including children) with reduced physical, sensory or mental capabilities, or lack of experience and knowledge, unless they have been given supervision or instruction concerning use of the appliance by a person responsible for their safety.
- Children should be supervised to ensure that they do not play with the appliance.
- If the supply cord is damaged, it must be replaced by the manufacturer, its service agent or similarly qualified persons in order to avoid a hazard.
- **WARNING:** Ensure that the appliance is switched off before replacing the lamp to avoid the possibility of electric shock.
- **WARNING:** It is hazardous for anyone other than a competent person to carry out any service or repair operation that involves the removal of a cover which gives protection against exposure to microwave energy.



SAFETY WARNING

IMPORTANT SAFETY INSTRUCTIONS

- **WARNING:** Liquids and other foods must not be heated in sealed containers since they are liable to explode.
- When heating food in plastic or paper containers, keep an eye on the oven due to the possibility of ignition.
- Only use utensils that are suitable for use in microwave ovens.
- If smoke is emitted, switch off or unplug the appliance and keep the door closed in order to stifle any flames.
- Microwave heating of beverages can result in delayed eruptive boiling, therefore care must be taken when handling the container.
- The contents of feeding bottles and baby food jars shall be stirred or shaken and the temperature checked before consumption, in order to avoid burns.
- Eggs in their shell and whole hard-boiled eggs should not be heated in microwave ovens since they may explode, even after microwave heating has ended.
- The oven should be cleaned regularly and any food deposits removed.
- Failure to maintain the oven in a clean condition could lead to deterioration of the surface that could adversely affect the life of the appliance and possibly result in a hazardous situation.



SAFETY WARNING

IMPORTANT SAFETY INSTRUCTIONS

- The appliance must not be installed behind a decorative door in order to avoid overheating. (This is not applicable for appliances with decorative door.)
- Only use the temperature probe recommended for this oven. (for ovens provided with a facility to use a temperature-sensing probe.)
- The microwave oven shall not be placed in a cabinet unless it has been tested in a cabinet.
- The microwave oven must be operated with the decorative door open. (for ovens with a decorative door.)
- This appliance is intended to be used in household and similar applications such as:
 - staff kitchen areas in shops, offices and other working environments;
 - by clients in hotels, motels and other residential type environments;
 - farm houses;
 - bed and breakfast type environments.
- The microwave oven is intended for heating food and beverages. Drying of food or clothing and heating of warming pads, slippers, sponges, damp cloth and similar may lead to risk of injury, ignition or fire.
- Metallic containers for food and beverages are not allowed during microwave cooking.



SAFETY WARNING

IMPORTANT SAFETY INSTRUCTIONS

- The appliance shall not be cleaned with a steam cleaner.
- The appliance is intended to be used freestanding.
- The rear surface of appliances shall be placed against a wall.
- Steam cleaner is not to be used.
- Surface of a storage drawer can get hot.
- Do not use harsh abrasive cleaners or sharp metal scrapers to clean the oven door glass since they can scratch the surface, which may result in shattering of the glass.
- **WARNING:** The appliance and its accessible parts become hot during use. Care should be taken to avoid touching heating elements. Children less than 8 years of age shall be kept away unless continuously supervised.
- During use the appliance becomes hot. Care should be taken to avoid touching heating elements inside the oven.
- **WARNING:** Accessible parts may become hot during use. Young children should be kept away.
- **WARNING:** When the appliance is operated in the combination mode, children should only use the oven under adult's supervision due to the temperatures generated.

READ CAREFULLY AND KEEP FOR FUTURE REFERENCE

PRECAUTIONS TO AVOID POSSIBLE EXPOSURE TO EXCESSIVE MICROWAVE ENERGY

- (a) Do not attempt to operate this oven with the door open since this can result in harmful exposure to microwave energy.
It is important not to break or tamper with the safety interlocks.
- (b) Do not place any object between the oven front face and the door or allow cleaner residue to accumulate on sealing surfaces.
- (c) **WARNING:** If the door or door seals are damaged, the oven must not be operated until it has been repaired by a competent person.

ADDENDUM

If the apparatus is not maintained in a good state of cleanliness, its surface could be degraded and affect the life span of the apparatus and lead to a dangerous situation.

SPECIFICATIONS

Model:	ML-EC42S(BS)
Rated Voltage:	230V~50Hz
Power Consumption (Microwave):	1550W
Rated Output Power (Microwave):	1000W
Rated Input(Grill):	1300W
Rated Input(Convection):	2700W

TO REDUCE THE RISK OF INJURY TO PERSONS GROUNDING INSTALLATION

DANGER

Electric Shock Hazard

Touching some of the internal components can cause serious personal injury or death. Do not disassemble this appliance.

WARNING

Electric Shock Hazard

Improper use of the grounding can result in electric shock. Do not plug into an outlet until appliance is properly installed and grounded.

This appliance must be grounded. In the event of an electrical short circuit, grounding reduces the risk of electric shock by providing an escape wire for the electric current.

This appliance is equipped with a cord having a grounding wire with a grounding plug. The plug must be plugged into an outlet that is properly installed and grounded.

Consult a qualified electrician or serviceman if the grounding instructions are not completely understood or if doubt exists as to whether the appliance is properly grounded.

If it is necessary to use an extension cord, use only a 3-wire extension cord.

1. A short power-supply cord is provided to reduce the risks resulting from becoming entangled in or tripping over a longer cord.
2. If a long cord set or extension cord is used:
 - 1) The marked electrical rating of the cord set or extension cord should be at least as great as the electrical rating of the appliance.
 - 2) The extension cord must be a grounding-type 3-wire cord.
 - 3) The long cord should be arranged so that it will not drape over the counter top or tabletop where it can be pulled on by children or tripped over unintentionally.

TO REDUCE THE RISK OF INJURY TO PERSONS GROUNDING INSTALLATION

CLEANING

Be sure to unplug the appliance from the power supply.

1. Clean the cavity of the oven after using with a slightly damp cloth.
2. Clean the accessories in the usual way in soapy water.
3. The door frame and seal and neighboring parts must be cleaned carefully with a damp cloth when they are dirty.
4. Do not use harsh abrasive cleaners or sharp metal scrapers to clean the oven door glass since they can scratch the surface, which may result in shattering of the glass.
5. Cleaning Tip---For easier cleaning of the cavity walls that the food cooked can touch: Place half a lemon in a bowl, add 300ml (1/2 pint) water and heat on 100% microwave power for 10 minutes. Wipe the oven clean using a soft, dry cloth.

UTENSILS

CAUTION

Personal Injury Hazard

It is hazardous for anyone other than a competent person to carry out any service or repair operation that involves the removal of a cover which gives protection against exposure to microwave energy.

See the instructions on "Materials you can use in microwave oven or to be avoided in microwave oven." There may be certain non-metallic utensils that are not safe to use for microwaving. If in doubt, you can test the utensil in question following the procedure below.

Utensil Test:

1. Fill a microwave-safe container with 1 cup of cold water (250ml) along with the utensil in question.
2. Cook on maximum power for 1 minute.
3. Carefully feel the utensil. If the empty utensil is warm, do not use it for microwave cooking.
4. Do not exceed 1 minute cooking time.

MATERIALS YOU CAN USE IN MICROWAVE OVEN

UTENSILS	REMARKS	
Browning dish	Follow manufacturer's instructions. The bottom of browning dish must be at least 3/16 inch (5mm) above the turntable. Incorrect usage may cause the turntable to break.	✓
Dinnerware	Microwave-safe only. Follow manufacturer's instructions. Do not use cracked or chipped dishes.	✓
Glass jars	Always remove lid. Use only to heat food until just warm. Most glass jars are not heat resistant and may break.	✓
Glassware	Heat-resistant oven glassware only. Make sure there is no metallic trim. Do not use cracked or chipped dishes.	✓
Oven cooking bags	Follow manufacturer's instructions. Do not close with metal tie. Make slits to allow steam to escape.	✓
Paper plates and cups	Use for short-term cooking/warming only. Do not leave oven unattended while cooking.	✓
Paper towels	Use to cover food for reheating and absorbing fat. Use with supervision for a short-term cooking only.	✓
Parchment paper	Use as a cover to prevent splattering or a wrap for steaming.	✓
Plastic	Microwave-safe only. Follow the manufacturer's instructions. Should be labeled "Microwave Safe". Some plastic containers soften, as the food inside gets hot. "Boiling bags" and tightly closed plastic bags should be slit, pierced or vented as directed by package.	✓
Plastic wrap	Microwave-safe only. Use to cover food during cooking to retain moisture. Do not allow plastic wrap to touch food.	✓
Wax paper	Use as a cover to prevent splattering and retain moisture.	✓

MATERIALS TO BE AVOIDED IN MICROWAVE OVEN

UTENSILS	REMARKS	
Aluminum tray	May cause arcing. Transfer food into microwave-safe dish.	✗
Food carton with metal handle	May cause arcing. Transfer food into microwave-safe dish.	✗
Metal or metal-trimmed utensils	Metal shields the food from microwave energy. Metal trim may cause arcing.	✗
Metal twist ties	May cause arcing and could cause a fire in the oven.	✗
Paper bags	May cause a fire in the oven.	✗
Plastic foam	Plastic foam may melt or contaminate the liquid inside when exposed to high temperature.	✗
Wood	Wood will dry out when used in the microwave oven and may split or crack.	✗

SETTING UP YOUR OVEN

Names of Oven Parts and Accessories

Remove the oven and all materials from the carton and oven cavity.

Your oven comes with the following accessories:

Glass tray	1
Turntable ring assembly	1
Turntable Shaft	1
Grill Rack	2
Instruction Manual	1
Bake Tray	1

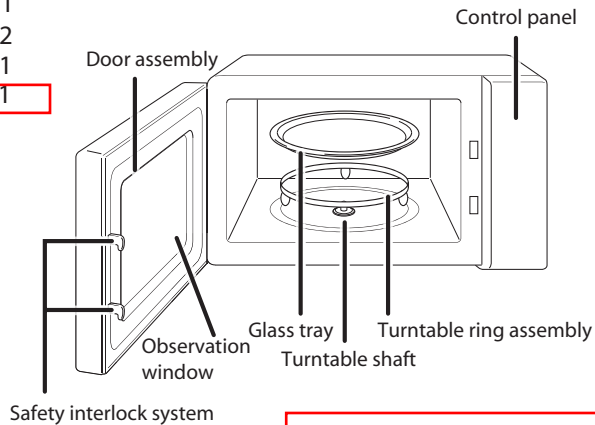

Grill Rack (Can not be used in microwave function and must be placed on the glass tray)

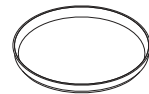

Bake Tray (Cannot be used in conjunction with microwave function and can be placed on the grill rack)

Turntable Installation

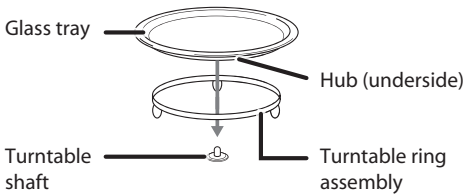

- Never place the glass tray upside down. Follow the instruction to place the glass tray on the turntable ring with correct direction. The glass tray should rotate smoothly.
- Both glass tray and turntable ring assembly must always be used during cooking.
- All food and containers of food are always placed on the glass tray for cooking.
- If glass tray or turntable ring assembly cracks or breaks, contact your nearest authorized service center.

SETTING UP YOUR OVEN

Countertop Installation

Remove all packing material and accessories. Examine the oven for any damage such as dents or broken door. Do not install if oven is damaged.

Cabinet: Remove any protective film found on the microwave oven cabinet surface. Do not remove the light brown Mica cover that is attached to the oven cavity to protect the magnetron.

Installation

1. Select a level surface that provide enough open space for the intake and/or outlet vents.

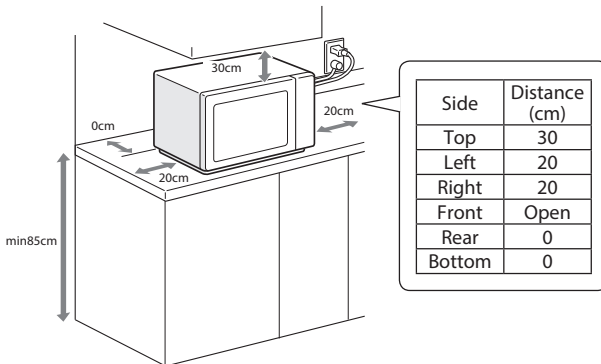

- (1) The minimum installation height is 85cm.
 - (2) The rear surface of appliance shall be placed against a wall.
Leave a minimum clearance of 30cm above the oven, a minimum clearance of 20cm is required between the oven and any adjacent walls.
 - (3) Do not remove the legs from the bottom of the oven.
 - (4) Blocking the intake and/ or outlet openings can damage the oven.
 - (5) Place the oven as far away from radios and TV as possible. Operation of microwave oven may cause interference to your radio or TV reception.
2. Plug your oven into a standard household outlet. Be sure the voltage and the frequency is the same as the voltage and the frequency on the rating label.

SETTING UP YOUR OVEN

**WARNING**

Do not install oven over a range cooktop or other heat-producing appliance.

If installed near or over a heat source, the oven could be damaged and the warranty would be void.



The accessible surface may be hot during operation.

OPERATION INSTRUCTIONS

CONTROL PANEL



OPERATION INSTRUCTIONS

1. CLOCK SETTING

When the microwave oven is electrified, the oven will display "0:00", buzzer will ring once.

The input time should be within 0:00--23:59(24 Hour) or 0:00--12:59(12 Hour).

- a. Press " Clock/ Pre-set" once, buzzer will ring once and "24H" displays.
- b. Press " Clock/ Pre-set" repeatedly to choose 24H or 12H system.
- c. Press the number buttons to set clock.
- d. Press " Clock/ Pre-set" to finish clock setting. ":" will flash, and the time will light.

NOTE

- If the clock is not set, it would not function when powered.
- During the process of clock setting, if you press "STOP/Cancel", the oven will go back to the previous status automatically.

2. MICROWAVE COOKING

Select different microwave power level and set cooking time as you wish. There are five power levels available for choosing. Keep on pressing "Micro." to choose the power.

Example: If you want to use 80% microwave power to cook for 10 minutes, you can operate the oven as the following steps.

- a. Press "Micro." once, the oven will display "P100".
- b. Press "Micro." once again to choose 80% power, the oven will display "P80".
- c. Press the number buttons of "1", "0", "0", "0" in order, the oven will display "10:00".
- d. Press "START/+30Sec." to start cooking, ":" will light.

NOTE

"Micro." Pad presses instructions

Presses Instructions	Display	Microwave Power
1	P100	100%
2	P80	80%
3	P50	50%
4	P30	30%
5	P10	10%

OPERATION INSTRUCTIONS

3. GRILL & COMBINATION COOKING

GRILL COOKING

Example: If you want to use grill to cooking for 35 minutes, you can operate the oven as the following steps.

- a. Press the "Grill/Combi" key once, the oven will display "G-1".
- b. Press the number buttons of "3", "5", "0", "0" in order, the oven will display "35:00"
- c. Press the "START/+30Sec." key to start cooking.

NOTE	If half the grill time passes, the oven sounds twice, and this is normal. In order to have a better effect of grilling food, you should turn the food over, close the door, and then press "START/+30Sec." to continue cooking. If no operation, the oven will continue working.
-------------	---

COMBINATION COOKING

Example: If you want to use combination to cook (C-1) for 40 minutes, you can operate the oven as per the following steps.

- a. Press the "Grill/Combi" key twice, the oven will display "C-1".
- b. Press the number buttons of "4", "0", "0", "0" in order, the oven will display "40:00".
- c. Press the "START/+30Sec." key to start cooking.

NOTE	"Grill/Combi" Pad presses instructions
-------------	--

Presses Instructions	Display	Microwave Power	Grill Power	Convection Power
1	G-1		●	
2	C-1	●		●
3	C-2	●	●	
4	C-3		●	●
5	C-4	●	●	●

OPERATION INSTRUCTIONS

4. REHEAT FUNCTION

a. Press "Reheat" pad once, the "h-1" will display and flash.

(Press the "Reheat" pad several times to select the cooking program you wanted.)

b. Press "START/+30Sec." key to confirm, the "h-1" will display.

c. Press "Reheat" pad, the oven will display "150".

(Press the "Reheat" pad several times to select the weight of the cooking food.)

d. Press "START/+30Sec." key to start cooking.

Reheat Chart

Menu	Weight(g)	Display
h-1 (Auto Reheat)	150	150
	250	250
	350	350
	450	450
	600	600
h-2 (Dinner Plate)	250	250
	350	350
	450	450
h-3 (Coffee)	1 cup(approximately 240g)	1
	2 cups(approximately 480g)	2
	3 cups(approximately 720g)	3
h-4 (Roll)	1 (approximately 70g)	1
	2 (approximately 140g)	2
	3 (approximately 210g)	3

5. CONVECTION COOKING

With preheating function

The convection cooking can let you to cook the food as a traditional oven. Microwave is not used. It is recommended that you should preheat the oven to the appropriate temperature before placing the food in the oven.

a. Press the "Conv." key once, the oven will display "140".

(Press the "Conv." key several times to select the temperature.)

Convection temperature is from 140 degrees to 230 degrees.

OPERATION INSTRUCTIONS

- b. Press the "START/+30Sec." key to start preheating. The temperature figure will flash when reach to the temperature in advance and buzzer will ring twice to remind you to put the food into the oven.
- c. Press the number buttons of "4","0","0","0" in order, the oven will display "40:00"
- d. Press the "START/+30Sec." key to start cooking.

NOTE

- Cooking time cannot be input until the preheating temperature arrives. If the temperature arrives, door must be opened to input the cooking time.
- If the time not input in 5 minutes, the oven will stop preheating. The buzzer sound five times and turn back to waiting state.

Without preheating function

- a. Press the "Conv." key once, the oven will display "140".
(Press the "Conv." key several times to select the temperature.)
Convection temperature is from 140 degrees to 230 degrees.
- b. Press the number buttons of "4","0","0","0" in order, the oven will display "40:00"
- c. Press the "START/+30Sec." key to start cooking.

6. HOME FRY COOKING

- a. Press "Home Fry" pad once, the "F1" will display in oven.
(Press the "Home Fry" pad several times to select the cooking program you wanted.)
- b. Press "START/+30Sec." key to start cooking.

OPERATION INSTRUCTIONS

Display	Menu	Weight(g)
F1	Frozen French fries	300g
F2	Frozen Potato croquettes	300g
F3	Frozen Squid	200g
F4	Frozen Onion rings	250g
F5	Frozen Chicken nuggets	400g
F6	Escalope	300g
F7	Shrimps	200g
F8	Vegetable	120g
F9	Spring Rolls	300g

7. DEFROST BY TIME

- a. Press "Defrost" pad once, the oven will display "d-1".
- b. Input the figure of the time of cooking.
(The maximum cooking time is 99 minutes and 99 seconds.)
- c. Press "START/+30Sec." key to start defrosting.

8. DEFROST BY WEIGHT

- a. Press "Defrost" pad twice, the oven will display "d-2".
- b. Input the figure of the weight of food.
(The input figure of the weight should be within 100--2000g.)
- c. Press "START/+30Sec." key to start defrosting.

9. DEFROST GROUND MEAT

- a. Press "Defrost" pad thrice, the oven will display "d-3".
- b. Input the figure of the weight of food.
(The input figure of the weight should be within 100--2000g.)
- c. Press "START/+30Sec." key to start defrosting.

OPERATION INSTRUCTIONS

10. DEFROST SEA FOOD

- a. Press "Defrost" pad 4 times, the oven will display "d-4".
- b. Input the figure of the weight of food.
(The input figure of the weight should be within 100--2000g.)
- c. Press "START/+30Sec." key to start defrosting.

11. PRE-SET FUNCTION

- a. Set the clock first. (Consult the instruction of clock setting.)
- b. Input the cooking program. Two stages can be set at most. Defrosting should not be set in pre-set function.
After setting cooking program, please do not press "START/+30Sec.". Then do as following:
- c. Press "Clock/Pre-set". "00:00" will display.
- d. Press the number buttons to set pre-set time.
- e. Press "START/+30Sec." to finish setting. ":" will light, buzzer will ring twice when the time arrives, then cooking will start automatically.

NOTE clock must be set first. Otherwise, pre-set function will not work.

12. AUTO MENU COOKING

The numeral pads 0--9 are matching with ten different subjects respectively.

Pad	Cook	Pad	Cook	Pad	Cook	Pad	Cook
1	Vegetable	4	Pasta	7	Roast	0	Pizza
2	Fish	5	Potato	8	Bread		
3	Meat	6	Soup	9	Cake		

Example: Cooking vegetable of 350g:

- a. Press "Vegetable" button.
- c. Press "Vegetable" button again to choose weight, oven will display "350".
- d. Press "START/+30Sec." to start cooking.

OPERATION INSTRUCTIONS

Auto Menu Chart

Menu	Weight	Press Times	Display
Vegetable	150g(with water 30g)	Once	150
	350g(with water 60g)	Twice	350
	500g(with water 120g)	Thrice	500
Fish	150g	Once	150
	250g	Twice	250
	350g	Thrice	350
	450g	4 times	450
	650g	5 times	650
Meat	150g	Once	150
	300g	Twice	300
	450g	Thrice	450
	600g	4 times	600
Pasta	50g(with cold water 450g)	Once	50
	100g(with cold water 800g)	Twice	100
	150g(with cold water 1200g)	Thrice	150
Potato	1(approximately 230g)	Once	1
	2(approximately 460g)	Twice	2
	3(approximately 690g)	Thrice	3
Soup	200ml	Once	200
	400ml	Twice	400
	600ml	Thrice	600
Roast	500g	Once	500
	750g	Twice	750
	1000g	Thrice	1000
	1200g	4 times	1200
Bread	50g	Once	50
	100g	Twice	100
	150g	Thrice	150
Cake	475g	Once	475
Pizza	200g	Once	200
	300g	Twice	300
	400g	Thrice	400

OPERATION INSTRUCTIONS

NOTE

- When you choose cake, please do not put the cake into the oven at the beginning.
The oven needs to be preheated to 180 degree first. After several minutes, the buzzer sounds twice to remind you to put the cake into the oven. After putting the cake in the oven, please press "START/+30Sec." again. The timer will count down, and the cake will be cooked perfectly.
- If you choose roast, cake or pizza, you should place the food on the grill rack at a height of 40 mm . If you choose roast, it's only for roasting chicken.

13. MEMORY FUNCTION

- a. Press "Memory" to choose memory 1-3 procedure. The screen will display 1,2,3.
- b. If the procedure has been set, press " START/+30Sec." to use it. If not, continue to set the procedure. Only one or two stages can be set.
- c. After finishing the setting, prese "Memory" to save the pcedure and turn back to the waiting state. If press "START/+30Sec.", the oven will save the procedure and start it.

NOTE

- If the electricity is cut off, the procedure that has been saved will be cancelled.
- Defrosting, preheating and auto menu cannot be set as memory procedure.

14. MULTI-STAGE COOKING

Two stages of cooking can be maximumly set. If one of the stages is defrosting, it will be put in the first stage automatically, and auto menu should not be set here. The buzzer will ring once after each stage and the next stage will begin.

Example: If you want to cook the food with 100% microwave power for 10 minutes + 80% microwave power for 15 minutes. Do it as following:

- a. Press "Micro." once to choose 100% microwave power.
- b. Press number keys "1","0","0","0" in order to adjust the cooking time.

OPERATION INSTRUCTIONS

- c. Press "Micro." twice to choose 80% microwave power.
- d. Press number keys "1","5","0","0" in order to adjust the cooking time.
- e. Press "START/+30Sec." to start cooking.

15. EXPRESS COOKING

When the oven is in the waiting state, press "START/+30Sec." key to start cooking with full microwave power for 30 seconds. Each press the same key can increase the cooking time for 30 seconds.(the maximum setting is 99 minutes and 99 seconds.)

When the oven is in the microwave, grill, convection and combination cooking states, press "START/+30Sec." key to add 30 seconds cooking time.(In the Weight Defrosting, Multi-stage Cooking or Auto Menu state is invalid.)

16. INQUIRING FUNCTION

- a. In cooking state, press "Grill/Combi", "Micro.", or "Conv.", and the current power will be displayed for 2~3 seconds.
- b. In pre-set state, press "Clock/Pre-set" to inquire the time for delay start cooking. The pre-set time will flash for 2~3 seconds, then the oven will turn back to the clock display.
- c. During cooking state, press "Clock/Pre-set" to check the current time. It will be displayed for 2~3 seconds.

17. LOCK FUNCTION FOR CHILDREN

Lock: In waiting state or 10 minutes passes after the end of auto menu cooking, if there is no operation within 1 minute, the oven will enter into the children-lock state and a key indicator will light. The oven will display "0:00" or current time.

Lock quitting: In children-lock state, open the door and a key indicator will go out denoting that the lock is released.

NOTE

- After the door-lock function is activated, pressing any keys the screen will display "door" for 3 seconds. Only the oven quits the door-lock state can the cooking procedure work.

OPERATION INSTRUCTIONS

NOTE

- When the oven is electrified with the door is close, the oven will enter the children-lock state automatically.

18. TURNTABLE RESET FUNCTION

a. When cooking finished, if the turntable is not at the initial position, it will enter the turntable reset function.

At this time, the lamp, fan and turntable are working, "E - - J" will dynamic display. After the turntable has reset, the oven stops cooking and reminds cooking finished.

b. In waiting state, press number key "5" for 3 seconds, there will be a long "beep" denoting turntable reset function is turned off. To turn on the turntable reset function, in waiting state press number key "5" for 3 seconds, there will be a long "beep" denoting that turntable reset function is released.

NOTE

- This function only works for one completed cooking. If pause or open the oven door during cooking, the current cooking cannot enter the turntable reset function.
- Under the reset state, opening the door or "STOP/CANCEL" button is pressed, the oven will go back to waiting state.

19. COOKING END REMINDING FUNCTION

When the cooking is over, the buzzer will sound 5 "beep" to alert user the cooking is finished.

20. DISPLAY SPECIFICATION

a. In waiting state, the oven will display clock and ":" will flash.

b. In function setting state, the oven will display the related setting.

c. In the operation and suspending state, the oven will display the residual cooking time.

d. Once the cooking programme has been set, "START/+30Sec." is not pressed in 5 minutes. The current time will be displayed. The setting will be cancelled.

TROUBLE SHOOTING

Normal	
Microwave oven interfering TV reception	Radio and TV reception may be interfered when microwave oven operating. It is similar to the interference of small electrical appliance, like mixer, vacuum cleaner, and electric fan. It is normal.
Dim oven light	In low power microwave cooking, oven light may become dim. It is normal.
Steam accumulating on door, hot air out of vents	In cooking, steam may come out of food. Most will get out from vents. But some may accumulate on cool place like oven door. It is normal.
Oven started accidentally with no food in.	It is forbidden to run the until without any food inside. It is very dangerous.

Trouble	Possible Cause	Remedy
Oven can not be started.	(1) Power cord not plugged in tightly.	Unplug. Then plug again after 10 seconds.
	(2) Fuse blowing or circuit breaker works.	Replace fuse or reset circuit breaker (repaired by professional personnel of our company)
	(3) Trouble with outlet.	Test outlet with other electrical appliances.
Oven does not heat.	(4) Door not closed well.	Close door well.



