

USER MANUAL

AIR FRYER
AF-50THVRTH(H)

TOSHIBA



CONTENTS

CONTENTS	01
SAFETY INSTRUCTIONS	02
SPECIFICATIONS	05
PRODUCT OVERVIEW	06
INSTRUCTIONS FOR USE	07
CLEANING AND MAINTENANCE	11
TROUBLESHOOTING	12

SAFETY INSTRUCTIONS

Intended Use

The following safety guidelines are intended to prevent unforeseen risks or damage from unsafe or incorrect operation of the appliance. Please check the packaging and appliance on arrival to make sure everything is intact to ensure safe operation. If you find any damage, please contact the retailer or dealer. Please note modifications or alterations to the appliance are not allowed for your safety concern. Unintended use may cause hazards and loss of warranty claims.

Explanation of Symbols



Danger

This symbol indicates that there are dangers to the life and health of persons due to extremely flammable gas.



Warning of electrical voltage

This symbol indicates that there is a danger to life and health of persons due to voltage.



Warning

The signal word indicates a hazard with a medium level of risk which, if not avoided, may result in death or serious injury.



Caution

The signal word indicates a hazard with a low degree of risk which, if not avoided, may result in minor or moderate injury.



Attention

The signal word indicates important information (e.g. damage to property), but not danger.



Observe instructions

This symbol indicates that a service technician should only operate and maintain this appliance in accordance with the operating instructions.

Read these operating instructions carefully and attentively before using/ commissioning the unit and keep them in the immediate vicinity of the installation site or unit for later use!

▲ WARNING

Safety Instructions

- If the supply cord is damaged, it must be replaced by the manufacturer, its service agent or similarly qualified persons in order to avoid a hazard.
- Do not immerse any part of the appliance in water or other liquid.
- Warning: Avoid spillage on the connector.
- Do not use outdoors.
- This appliance is intended to be used in household and similar applications such as:
 - Staff kitchen areas in shops, office and other working environments;
 - farm houses;
 - by clients in hotels, motels and other residential type environments;
 - In bed and breakfast type environments;
- This appliance is not intended for use by persons (including children) with reduced physical, sensory or mental capabilities, or lack of experience and knowledge, unless they have been given supervision or instruction concerning use of the appliance by a person responsible for their safety.
- Children should be supervised to ensure that they do not play with the appliance.
- Appliances are not intended to be operated by means of an external timer or separate remote-control system.
- Warning: Misuse may cause potential injury.
- WARNING: If the surface is cracked, switch off the appliance to avoid the possibility of electric shock.
- Always put the ingredients to be fried in the basket, to prevent it from coming into contact with the heating elements.

- Do not cover the air inlet and the air outlet openings while the appliance is operating.
- Do not fill the pan with oil as this may cause a fire hazard. Never touch the inside of the appliance while it is operating.
- During hot air frying, hot steam is released through the air outlet openings. Keep your hands and face at a safe distance from the steam and from the air outlet openings.
- Also be careful of hot steam and air when you remove the pan from the appliance.
Immediately unplug the appliance if you see dark smoke coming out of the appliance. Wait for the smoke emission to stop before you remove the pan from the appliance.
-  The surface are liable to get hot during use.

SPECIFICATIONS

Product Model	AF-50THVRTH(H)
Capacity	5L
Rated voltage	220-240V~
Rated frequency	50/60Hz
Rated power	1400-1600W
Electrical appliance type	I
Packing size	372 x 276 x 295mm
Weight	46kg
Effective Power Cord Length	0.8m

PRODUCT OVERVIEW

Part Name

The product is subject to the actual product and configuration.

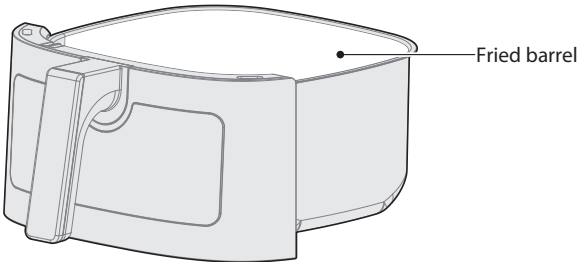
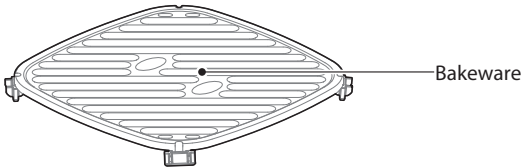
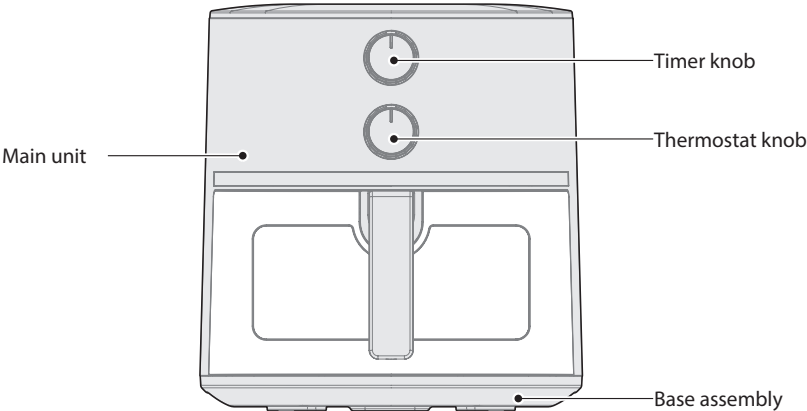

INSTRUCTIONS FOR USE

Preparation

1. The product should be stably placed on a flat table (Figure 1), so that the power cord has a sufficient length to be plugged into the socket, and the air around the product should be kept in circulation, and should not be close to flammable items.

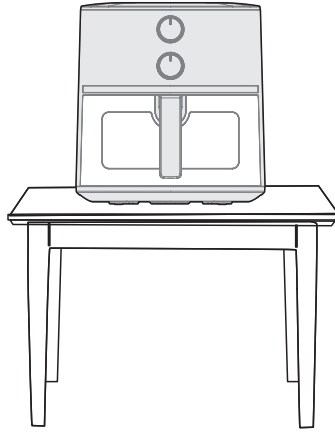

Figure 1

2. According to different configurations install the barrel assembly (Figure 2), then push it into the Main unit (Figure 3).

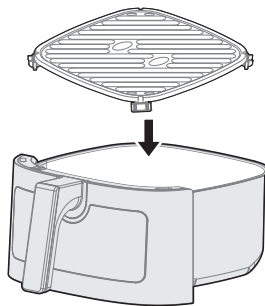

Figure 2

Tips For Fried barrel

When assembling fried barrel, the sound of metal duckles proves that the assembly is in place.

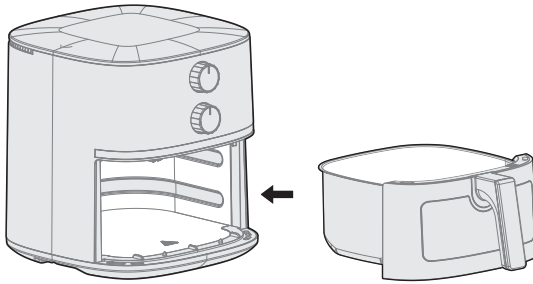
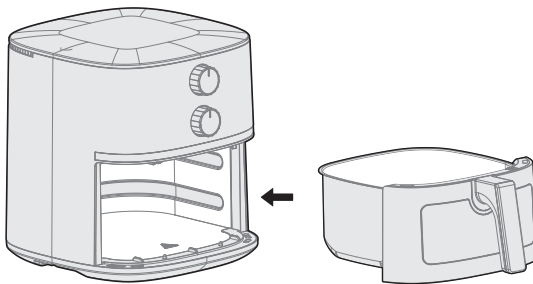

Figure 3

3. Before placing ingredients, preheat the machine for 3-5 minutes, the cooking effect will be better.

Instructions

1. After the machine is powered on, adjust the temperature knob to the 200°C position and the time knob to 3-5 minutes to complete the warm-up operation of the machine.
2. After the preheating is completed, hold the top of the machine with one hand, and pull the barrel out by holding the handle of the barrel with the other hand. The barrel must be placed on a stable table.
3. Put the ingredients on the bakeware in the fried barrel.
4. Push the fryer into the machine, select the corresponding cooking temperature and time by the knob, and cook and heat the ingredients.



NOTE

When the drum is not fully advanced, the micro-switch is not triggered, the machine is in the state of power off the barrel, and it will not work. At this time, you only need to fully push the drum.

5. After the timer “ding”, the heating is completed. When the food is ready, unplug it. Take out the fryer carefully, lay it flat on the table, and then use the auxiliary tools (such as chopsticks) to remove the cooked food.

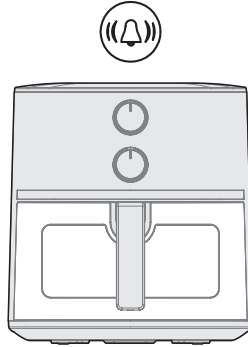

Tips For Timer

If you set the scale within 30 degrees (about 10 mins) from the OFF position, roll to more than 30 degrees and then adjust to the required scale.



Handle with care and remember to lay it flat on the table to avoid being burned by steam or dumping the fryer, or burned by oil or hot food. In the process of removing food, it is recommended to use auxiliary tools (such as chopsticks) to assist.

Warm reminder

- The first use requires 10 minutes of dry burning. A small amount of white smoke or odor may appear during the dry burning process, which is normal.
Do not panic.
- Before the product works, please check whether the bakeware is in place to avoid malfunction.
- If you find that the product is malfunctioning, please stop using it and contact our service department immediately.
- Please use the bakeware and fried barrel together in the whole machine, and avoid using them separately.
- After using, unplug the power plug and allow the air fryer to cool completely before moving.

Settings

This table below helps you to select the basic settings for the ingredients you want to prepare.

Menus	Temperature (°C)	Time(min.)
Defrost	80	11-13
Frozen fries	180	17-19
Chicken wing	180	16-18
Chicken legs	180	20-22
Meat	190	9-11
Shrimp	180	10-12
Fish	180	11-13
Cake	170	10-12

CLEANING AND MAINTENANCE

- Please clean the air fryer to prevent it from being burned.
- After using, please clean the bakeware and fried barrel in time to avoid the damage of the coating due to the erosion of food residue oil.
- Do not use strong abrasive cleaners to prevent damage to the machine and your health.
- Use a soft, clean cloth to wipe the air fryer. Please do not use an over-wet cloth to clean the air fryer, to prevent water from entering the air fryer, which may cause short circuit and fire.
- Please do not use other cleaning equipment such as a dishwasher to clean the air fryer, otherwise it may cause damage and affect the use.
- Use neutral detergent or clean water to clean the bakeware and fried barrel.
- Please do not use hard and sharp items (such as wire balls, blades, etc.) to clean the bakeware and fried barrel to prevent scratching.
- Any other servicing should be performed by an authorized service representative.

TROUBLESHOOTING

Operation of your appliance can lead to errors and malfunctions. The following tables contain possible causes and notes for resolving an error message or malfunction. It is recommended to read the tables carefully below in order to save your time and money that may cost for calling to the service center.

Problem	Cause	Solution
The air fryer does not work	<ul style="list-style-type: none"> The appliance is not plugged in. 	Put the mains plug in an earthed wall socket.
	<ul style="list-style-type: none"> The fried barrel is not put into the appliance properly. 	Slide the fried barrel into the appliance properly.
The ingredients fried with the air fryer are not done.	<ul style="list-style-type: none"> The amount of ingredients in the fried barrel is too big. 	Put smaller batches of ingredients in the fried barrel . Smaller batches are fried more evenly.
	<ul style="list-style-type: none"> The set temperature is too low. 	Adjust the temperature to the required temperature setting.
	<ul style="list-style-type: none"> The preparation time is too short. 	Turn the timer key to the required preparation time.
The ingredients are fried unevenly in the air fryer.	<ul style="list-style-type: none"> Certain types of ingredients need to be shaken halfway through the preparation time. 	Ingredients that lie on top of or across each other (e.g.fries) need to be shaken halfway through the preparation time.
Fried snacks are not crispy when they come out of the air fryer.	<ul style="list-style-type: none"> You used a type of snacks meant to be prepared in a traditional deep fryer. 	Use oven snacks or lightly brush some oil onto the snacks for a crispier result.
I cannot slide the barrel into the appliance properly.	<ul style="list-style-type: none"> There are too much ingredients in the fried barrel. 	DO NOT fill the fried barrel beyond in full.
	<ul style="list-style-type: none"> The fried barrel is not placed, in the cavity correctly. 	Push the fried barrel down into the cavity until you hear a click.

Problem	Cause	Solution
White smoke comes out of the appliance.	<ul style="list-style-type: none"> You are preparing greasy ingredients. 	When you fry greasy ingredients in the air fryer, a large amount of oil will leak into the fried barrel . The oil produces white smoke and the fried barrel may heat up more than usual. This does not affect the appliance or the end result.
	<ul style="list-style-type: none"> The pan still contains grease residues from previous use. 	White smoke is caused by grease heating up in the fried barrel . Make sure you clean the fried barrel properly after each use.
Fresh fries are fried unevenly in the air fryer.	<ul style="list-style-type: none"> You did not use the right potato type. 	Use fresh potatoes and make sure they stay firm, during frying.
	<ul style="list-style-type: none"> You did not rinse the potato sticks properly before you fried them. 	Rinse the potato sticks properly to remove starch from the outside of the sticks.
Fresh fries are not crispy when they come out of the air fryer.	<ul style="list-style-type: none"> The crispiness of the fries depends on the amount of oil and water in the fries. 	Make sure you dry the potato sticks properly before you add the oil.
		Cut the potato sticks smaller for a crispier result.
		Add slightly more oil for a crispier result.

#DetailsMatter

Contact Information
TOSHIBA CONTACT CENTER 0-2511-7777
www.toshiba-lifestyle.com/th

